

SOLO

ELECTRAMECCANICA

OWNER'S MANUAL

Table of Contents

SECTION 1: INTRODUCTION

Information About This Manual	1-1
A Message to You from ElectraMeccanica	1-1
Symbols Glossary	1-1
About This Manual	1-1
On Vehicle References	1-2
Safety Information	1-3
Know How the SOLO is Different	1-3
Driver Requirements	1-4
Warning Labels	1-5
Vehicle Modifications and Accessories	1-5
Additional Required Equipment	1-5
Information About Your Vehicle	1-6
Electric Vehicle Operation	1-6
Vehicle Range	1-6
Vehicle Telematics	1-7
Vehicle Identification Number (VIN)	1-8
Specifications	1-9
Vehicle Specifications	1-9
Consumer Information	1-11
California Proposition 65 Warning	1-11
California Perchlorate Advisory	1-11
Frequently Asked Questions	1-12

SECTION 2: BEFORE YOU DRIVE

General Information	2-1
Safe Operation	2-1
Vehicle Load Limits	2-3
Pre-Drive Inspections	2-5
Pre-Drive Inspections	2-5
Pre-Drive Inspection Checklist	2-5

SECTION 3: SEAT AND SEAT BELT

Seat	3-1
Correct Seating Position	3-1
Seat Adjustment	3-2
Seat Belt	3-4
Using the Seat Belt	3-4
Seat Belt Safety	3-4
Fastening and Releasing the Seat Belt	3-5
Wearing the Seat Belt when Pregnant	3-6
Caring for the Seat Belt	3-7

SECTION 4: CONTROLS AND FEATURES



Interior Overview	4-1
Controls Overview	4-2
Steering Wheel	4-4
Steering Wheel Position	4-4
Horn	4-4
Mirrors	4-5
Exterior Power Mirrors	4-5
Starting and Drive Selection	4-6
Key Switch	4-6
Drive Mode Selector	4-7
Instrument Panel	4-9
Instrument Cluster Display	4-9
Indicator Lights	4-14
Warning Lights	4-15
Warning Light Combinations	4-16
Back-Up Camera	4-17
Brakes	4-18
Electronic Parking Brake (EPB)	4-18
Lights	4-20
Exterior Lights	4-20
Exterior Light Control	4-21
Interior Lights	4-24

Wiper and Washer	4-25
Windshield Wiper/Washer Lever	4-25
Locking and Unlocking the Vehicle	4-26
Remote Keyless Entry (RKE) System	4-26
Remote Transmitter	4-26
Hood	4-28
Hood	4-28
Heating and Ventilation	4-29
Climate Controls	4-29
Air Outlets	4-31
Power Windows	4-31
Seat Heater	4-32
Storage	4-33
Storage Space	4-33
Trunk	4-33
Cup Holder	4-35

Table of Contents

SECTION 5: BATTERY AND CHARGING



High-Voltage Battery Information	5-1
High-Voltage Components	5-1
About the High-Voltage Battery	5-2
Battery Care	5-2
Charging Instructions	5-3
Charging the Vehicle	5-3
Using the Charge Cable	5-3
Connecting the Charge Cable	5-4
Estimating Charging Time	5-7
Disconnecting the Charge Cable	5-7

SECTION 6: DRIVING AND OPERATING



Driving Precautions	6-1
Distracted Driving	6-1
Defensive Driving	6-1
Impaired Driving	6-2
Operating the Vehicle	6-3
Starting the Vehicle	6-3
Braking	6-5
Regenerative Braking	6-6
Parking	6-7

SECTION 7: MAINTENANCE



Maintenance Requirements	7-1
General Information	7-1
Owner Maintenance	7-1
Initial Required Maintenance	7-2
Scheduled Maintenance	7-2
Parts and Maintenance Items	7-2
Maintenance Safety Information	7-3
General Maintenance Safety Information	7-3
High-Voltage Safety Information	7-3
Maintenance Schedule	7-4
Maintenance Schedule Chart	7-4
Full Inspection Service	7-5
Under the Hood	7-7
Maintenance Cover	7-7
Component Locations	7-7
Brakes	7-8
Brake Fluid	7-8
Windshield Washer and Wiper	7-10
Washer Fluid	7-10
Checking the Wiper Blade	7-11
Replacing the Wiper Blade	7-11
Coolant	7-12
Battery and Drive Motor Coolant	7-12

Drive Belt	7-13
Checking Drive Belt Tension	7-13
Wheels and Tires	7-14
Inspection and Maintenance	7-14
Tire Pressures	7-17
Replacement Wheels and Tires	7-18
Tire Chains Prohibited	7-18
Tire Markings	7-19
Uniform Tire Quality Grading	7-21
Tires and Wheels Glossary	7-23
Lights and Fuses	7-25
Headlight/Bulb Replacement	7-25
Fuses	7-25
Accessing the Fuse Centers	7-26
Under-Hood Fuse Center	7-27
Interior Fuse Center	7-29
Batteries	7-30
Batteries	7-30
About the 12V Battery	7-30
Charging the 12V Battery	7-31
Remote Keyless Entry (RKE) Transmitter Battery Replacement	7-35
Cleaning and Care	7-37
Washing the Vehicle	7-37
Floor Mat	7-38
Parking and Long-Term Storage	7-39

Vehicle Lifting Points	7-41
Jacking and Lifting the Vehicle	7-41
Vehicle Recovery	7-42
Transporting the Vehicle	7-42
Using the Recovery Eye	7-44

SECTION 8: CUSTOMER INFORMATION

Customer Information	8-1
Customer Assistance	8-1
Reporting Safety Defects	8-2

SECTION 9: MAINTENANCE RECORD

Service History	9-1
Service History	9-1
Component Replacement Record	9-3
Replacement Record	9-3

SECTION 10: INDEX



A Message to You from ElectraMeccanica

Congratulations, and thank you for purchasing the SOLO all-electric, single-occupant, three-wheeled commuter vehicle.

This manual is designed to provide you with a better understanding of the operation, inspection, and basic maintenance requirements of this vehicle.

ElectraMeccanica Vehicles Corporation continually seeks advancements in product design and quality. Therefore, this manual contains the most current product information available at the time of printing. Because of this, your SOLO may differ from the information supplied in this owner's manual. No legal claims can be made on the basis of data in this manual.

Note: If you choose to sell your SOLO, please remember to hand over this manual; it is, by law, an important part of the vehicle. Transfer of ownership requires the new SOLO owner to contact ElectraMeccanica to deactivate the previous user and register the new user on the Solo App mobile application. See [“Customer Assistance”](#), page 8-1.

Always use and operate your vehicle in line with all applicable laws and regulations. If you have any questions concerning the operation or maintenance of your vehicle, please contact ElectraMeccanica. See [“Customer Assistance”](#), page 8-1.

Symbols Glossary

The following symbols found on vehicle labels and used within this manual call your attention to specific types of hazards and what to do to avoid or reduce them.

 **DANGER** Indicates a hazardous situation that, if not avoided, will result in death or serious injury.

 **WARNING** Indicates a hazardous situation that, if not avoided, could result in death or serious injury.

 **CAUTION** Indicates a situation that, if not avoided, could result in vehicle or property damage.



This symbol indicates risk of electric shock. Obey all safety messages that follow this symbol to avoid possible injury or death.



This symbol is used to alert you to potential physical injury hazards. Obey all safety messages that follow this symbol to avoid possible injury or death.

About This Manual

This manual covers the SOLO vehicle for models manufactured for 2021.



On Vehicle References

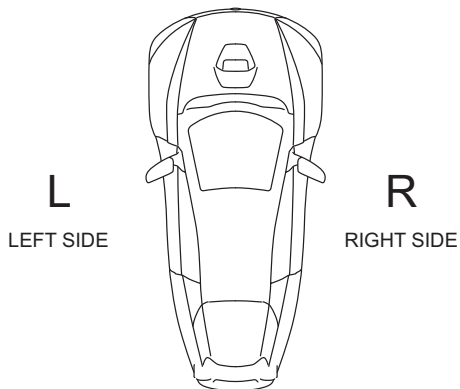

The terms **Left** or **Right** refer to the driver's left or right when sitting in the vehicle.





Know How the SOLO is Different

What kind of vehicle is the SOLO?

The SOLO is a three-wheeled, single-occupant passenger electric vehicle with an enclosed cabin. Three-wheeled vehicles with seats and steering wheels, rather than saddles and handlebars, are often called “autocycles” because they are classified by some regulations as motorcycles, but have some characteristics that are more typical of automobiles.

The National Highway Traffic Safety Administration (NHTSA) defines “motorcycle” as “a motor vehicle with motive power having a seat or saddle for the use of the rider and designed to travel on not more than three wheels in contact with ground” (49 CFR 571.3). Therefore, the SOLO is required to meet motorcycle safety standards, not passenger car safety standards.

How does the SOLO compare to motorcycles and automobiles in terms of safety?

When you choose a vehicle, you should consider safety. Every vehicle has different safety characteristics. The SOLO meets motorcycle safety standards, and has safety advantages when compared to a conventional motorcycle. The seatbelt and enclosed structure of the vehicle provide protection that a typical motorcycle lacks. The three-wheeled design provides stability to help avoid certain common types of motorcycle

accidents. Compared to a conventional motorcycle, the SOLO is generally the safer choice.

The SOLO is not designed or tested to meet all motor vehicle safety standards. While it does meet some requirements (such as seat retention, seatbelt anchorages, head restraints, roof crush resistance, and backup cameras), it does not meet or has not been tested for other requirements (such as occupant crash protection or rollover resistance).

NHTSA’s New Car Assessment Program (NCAP) provides 5-star safety rating for automobiles. Similarly, the Insurance Institute for Highway Safety (IIHS) rates automobile safety based on tests that differ slightly from NHTSA’s NCAP. Because the SOLO is not an automobile and has not been tested to the same standards, it does not have a rating from NCAP or IIHS.

In summary, while the SOLO is generally safer than a typical motorcycle, it presents a greater risk of injury or death compared to a contemporary automobile.

Two important factors in vehicle safety are *crash avoidance* (the ability of a vehicle to help you avoid a crash), and *crashworthiness* (the ability of the vehicle to protect an occupant in a crash).



Crash avoidance starts with the basic maneuverability of your vehicle: how well can it brake, steer, and accelerate. The SOLO provides the ability to maneuver nimbly. In addition, it has torque-limiting traction control to help prevent the drive wheel from operating at high levels of slip during acceleration and turning situations.

The SOLO has a full complement of standard features like power steering, power brakes, and a conventional spring/shock suspension system. It does not currently have seat belt pretensioners, anti-lock brakes, or air bags that are sometimes offered on other vehicles.

The vehicle does have a roll bar as well as triple side-impact door reinforcement.

Like all electric vehicles, the high-voltage battery in the SOLO can present electrical and fire hazards, particularly if a collision damages the electrical system. The SOLO Emergency Response Guide and Emergency Response Card provide detailed information on safely responding to such emergencies. These documents are made available to first responders so that they can be prepared to assist in an emergency. Both documents can be found at: <https://electrameccanica.com/firstresponders/>

Driver Requirements

Drivers who cannot comfortably reach the controls and adjust the seat or seat belt properly should not operate the SOLO.

For more information on these topics, see:

- [“Correct Seating Position”, page 3-1](#)
- [“Seat Belt”, page 3-4](#)

To determine proper vehicle loading for your SOLO, always refer to the Tire and Loading Information label on the vehicle. For more details, see [“Vehicle Load Limits”, page 2-3](#).

Licensing

In some jurisdictions (including Nebraska as of 2021), a motorcycle license is required to operate the SOLO. Check your state and local regulations.

Helmet

While most jurisdictions do not require a helmet for operators of enclosed three-wheeled vehicles, some jurisdictions (including Nebraska as of 2021) may require you to wear a helmet. Check your state and local regulations.



Warning Labels

Warning labels are located on the vehicle to alert the operator and/or any service technicians who may be working on the vehicle to potential safety hazards that exist, and to the related precautions that must be taken. Always follow these warnings to reduce the risk of serious injury or death and to ensure safe vehicle operation and maintenance. If any label becomes damaged, painted over, missing, or unreadable, have it replaced immediately. Contact an ElectraMeccanica Authorized Repair Facility.

Vehicle Modifications and Accessories

 **CAUTION** Installation and use of parts and accessories on your SOLO that are not approved by ElectraMeccanica may affect handling, exceed the vehicle's weight rating, cause extensive damage to the vehicle, interfere with the vehicle's electrical system, or void the SOLO New Vehicle Limited Warranties.

SOLO accessories are designed to complement and function with other systems on your vehicle. Go to store.electrameccanica.com to see the list of approved accessories. ElectraMeccanica is unable to accept any liability whatsoever for parts and accessories that have not been approved.

Additional Required Equipment

Regulations (such as those issued by the Federal Highway Administration, the National Highway Traffic Safety Administration (NHTSA), or issued pursuant to the Occupational Safety and Health Act (OSHA), and/or state and local laws and regulations) may require additional equipment for the way you intend to use the vehicle. The registered owner is responsible for determining which laws and regulations are applicable to the intended use of the vehicle, as well as arranging for the installation of any required equipment.

Contact ElectraMeccanica for information regarding optional equipment available for your vehicle. See [“Customer Assistance”, page 8-1](#).



Electric Vehicle Operation

This electric vehicle (EV) operates mainly from electricity stored in the on-board 144V high-voltage battery. The 12V accessory battery charges mainly from the 144V battery pack, and it can also be charged separately. Thus, the EV operates from both the 144V and the 12V systems. There is no internal combustion engine as in a typical vehicle or hybrid electric vehicle, which leads to unique operating characteristics. Familiarizing yourself with these unique characteristics will help ensure optimal performance from your new vehicle.



WARNING Keep in mind that pedestrians or other drivers may not hear your vehicle approaching. Use the horn when necessary to alert others to your presence.

- EVs operate with no engine noise; you may hear a soft whirring sound and tire noise. The SOLO does not generate a pedestrian-alerting sound.
- EVs generally have quicker acceleration than vehicles with internal combustion engines. Take some time in a safe area to test drive the vehicle and get used to the responsiveness of the accelerator pedal. See [“Safe Operation”, page 2-1](#).
- As the charge level of the battery decreases, you may experience a reduction in vehicle acceleration. The use of other electrical systems (e.g. climate controls, heated seat, radio) will further affect this reduction.

- The vehicle will not operate at ambient temperatures below -4°F (-20°C).

Vehicle Range

The range of an electric vehicle is defined as the distance the vehicle travels on a single full charge of the battery pack. Just like EPA (Environmental Protection Agency) mileage estimates on a typical vehicle, “your mileage may vary.” Your range results are a direct reflection of your driving habits. The more conservatively you drive, the better range you can expect from your SOLO.

Some of the factors that may affect range include speed, acceleration, climate control settings, number of starts and stops, ambient air temperature, and changes in elevation. As you travel from one point to another, the combination of these factors defines your trip profile. In addition, tire pressure and payload are important considerations.

ElectraMeccanica recommends that you drive conservatively until you get to know your vehicle and commute. Once you become familiar with the range versus performance of your vehicle, you can adjust your driving characteristics as needed. This applies mainly to drivers with trip profiles which are at the edge of the battery pack range.



Vehicle Telematics

Your SOLO is equipped with electronic modules that monitor and record data from various vehicle systems, including the motor, driver assistance components, battery, braking and electrical systems. The electronic modules record information about various driving and vehicle conditions, including braking, acceleration, mileage, and other related information regarding your vehicle. These modules also record information about the vehicle's features, such as charging events and status, the enabling and disabling of various systems, diagnostic trouble codes, Vehicle Identification Number, speed, direction, and location.

The data is stored by the vehicle and may be accessed, used, and stored by ElectraMeccanica vehicle service technicians during vehicle servicing, or periodically transmitted to ElectraMeccanica wirelessly through the vehicle's telematics system. This data may be used by ElectraMeccanica for various purposes, including, but not limited to: providing you with ElectraMeccanica telematics services; troubleshooting; evaluation of your vehicle's quality, functionality and performance; analysis and research by ElectraMeccanica and its partners for the improvement and design of our vehicles and systems; and as otherwise may be required by law. In servicing your vehicle, we can potentially resolve issues remotely simply by reviewing your vehicle's data log.

ElectraMeccanica's telematics system wirelessly transmits vehicle information to ElectraMeccanica on a periodic basis. The data is used as described above and helps ensure the proper maintenance of your vehicle. Additional SOLO features may use your vehicle's telematics system and provide features such as charging reminders, software updates, and control of various systems of your vehicle.

ElectraMeccanica does not disclose the data recorded in your vehicle to any third party, except when:

- An agreement or consent from the vehicle's owner (or leasing company for a leased vehicle) is obtained
- Officially requested by the police or other authorities
- Used as a defense for ElectraMeccanica in a lawsuit
- Ordered by a court of law
- Used for research purposes without disclosure details of the vehicle's owner or identification information
- Disclosure to an ElectraMeccanica-affiliated company, including their successors or assigns, or other information-systems and data-management providers

In addition, ElectraMeccanica does not disclose the data recorded to an owner unless it pertains to a non-warranty repair service (and, in this case, will only disclose the data related to the repair).



Vehicle Identification Number (VIN)

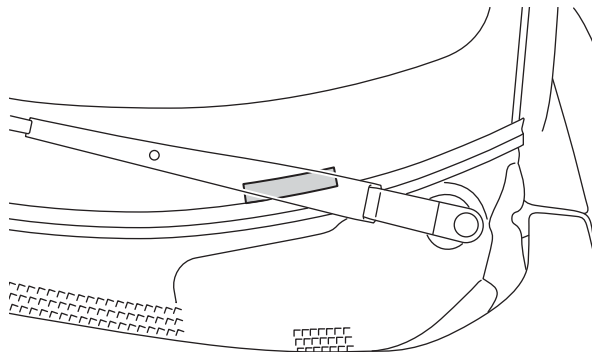

This legal identifier is in the front corner of the instrument panel. It can be viewed from outside the vehicle.

The VIN is also printed on the Tire and Loading Information label. See [“Vehicle Load Limits”, page 2-3.](#)





Vehicle Specifications

Range	Up to 100 mi (160 km) range
Charging Time	220V: 2.5 hrs 0-80%, 4 hrs 0-100% est* 120V: 12 hrs 0-80%, 15 hrs 0-100% est*
Acceleration	0-60 mph (0-100 km/h): 12 seconds est*
Top Speed	80 mph (130 km/h)
Motor	Synchronous Motor
	Torque: 103 ft-lb (140 Nm)
	Peak Motor Power Output: 56 hp (42 kW)
High-Voltage Battery	Lithium Ion 144V
	Energy Capacity: 17.4 kWh
Accessory Battery	12V
Electric Drive	Rear Wheel Drive
Vehicle Curb Weight	1735 lb (787 kg) estimated
Cargo Space	5 ft ³ (0.14 m ³)
Wheels	Front: 15" X 4.5", 4X100 ET33
	Rear: 16" X 7", 4X100 ET45

Tires	Front: 135/70R15 All-Season Rear: 215/40R16 All-Season
Safety	3-Wheel Power Disc Brakes
	Electronic Parking Brake
	Daytime Running Lights
	3-Point Seat Belt System
	Collapsible Steering Column

Note: All specifications subject to change without notice



Vehicle dimensions

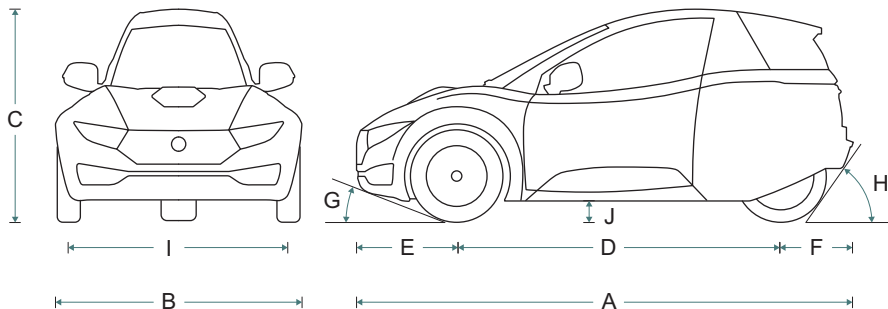

A	Length	10.18 ft	3103 mm
B	Overall Width	5.10 ft	1553 mm
C	Overall Height	4.38 ft	1334 mm
D	Wheel Base	6.64 ft	2024 mm
E	Front Overhang	24.57 in	624 mm
F	Rear Overhang	17.91 in	455 mm
G	Approach Angle	20.5°	20.5°
H	Departure Angle	55.5°	55.5°
I	Track - Front	4.52 ft	1379 mm
J	Ground Clearance	5.20 in	132 mm



California Proposition 65 Warning

⚠️ WARNING Certain vehicle components contain or emit chemicals known to the State of California to cause cancer and birth defects or other reproductive harm. In addition, certain fluids contained in vehicles and certain products of component wear contain or emit chemicals known to the State of California to cause cancer and birth defects or other reproductive harm. See the official website for more information: <https://oehha.ca.gov/proposition-65>

California Perchlorate Advisory

⚠️ WARNING Certain components of this vehicle (such as lithium batteries) may contain perchlorate material.

Special handling may apply when servicing or for end-of-life disposal. See the official website for more information: <https://www.dtsc.ca.gov/>





Frequently Asked Questions

How much weight can my vehicle carry?

To determine the amount of weight your SOLO can carry, always refer to the Tire and Loading Information label on the vehicle. For more details, see [“Vehicle Load Limits”, page 2-3](#).

Does weight affect range?

Added weight = reduced range

Yes. The more weight you are pushing, the more energy it takes to complete a journey. Avoid keeping unnecessary items in your vehicle, since it will impact your overall range.

Does acceleration affect range?

Hard acceleration = reduced range

Yes. Acceleration is the rate at which you are attempting to increase the speed of your vehicle. The greater the acceleration, the faster you are depleting the energy in the high-voltage battery. The harder and more frequently you accelerate, the more adversely you will affect the range of your vehicle. Being “first off the line” means you will also be the first to deplete your energy supply.

Will I get less range at higher speed?

Faster speed = reduced range

Yes. It takes more energy to push a SOLO faster because you

encounter aerodynamic resistance. The faster you attempt to travel, the more important this factor becomes.

Can I jump-start my vehicle when the high-voltage battery state of charge reaches 0%?

No. A jump start only supplies power to the 12V electrical system; this will not affect the charge level of the high-voltage battery. The high-voltage battery must be charged using the supplied charge cable and an approved power source.

The 12V battery should be jump-started using a standalone 12V battery or a 12V booster pack. It is NOT recommended to jump-start the 12V battery from any running vehicle (EV or internal combustion engine), as this risks damage to the vehicle.

For more information on your vehicle’s battery systems, see:

- [“About the High-Voltage Battery”, page 5-2](#)
- [“About the 12V Battery”, page 7-30](#)

Can I jump-start another vehicle with my SOLO?

No. The 12V battery system is not designed to support the energy needed to jump-start a vehicle with an internal combustion engine. Attempting to do so could cause severe damage to your vehicle, which would not be covered by the warranty.



Safe Operation

Single-occupant vehicle

The SOLO is a single-occupant vehicle, and is therefore not equipped to safely convey any passengers. Do not attempt to drive with passengers seated in the lap of the driver or seated in the cargo spaces. Do not attempt to install an infant carrier or a child safety seat anywhere in the vehicle.

Practice

Before you drive on the open road, look for a safe, legal, open area to familiarize yourself with the controls, stopping, starting, parking, and handling characteristics of your SOLO. Become familiar with the vehicle's handling during quick maneuvers. Try different types of braking, swerving, and turning.

Familiarize yourself with all of the controls, such as the wiper, exterior lights, and climate controls.

Lane positioning

Position your SOLO within the lane where you can be seen by other drivers. Typically, riding in the driver-side wheel track offers good visibility.

If you are used to driving a car, remember that you are centered in the vehicle, rather than seated to the side, so your perspective is different.

Keep all three wheels on the road. If you put one wheel off the road, you can lose control. If a wheel does go off the paved surface, do not try to rapidly steer it back on. Instead, stabilize the vehicle, ease up on the accelerator, and then steer slowly and smoothly back onto the paved surface.

Turning

When entering a turn, remember to slow down, look, and steer through the entire turn. Reduce speed as needed before entering a turn by easing up on the accelerator pedal or using the brakes. Enter the turn at a speed that you can maintain throughout the turn. Although your SOLO is better able to brake while turning than a motorcycle, it is still important to slow down before you enter a turn or curve rather than braking during the turn.

Tire failure

If your SOLO has a tire failure or a blowout, firmly grip the steering wheel, gradually slow down, and carefully steer to a safe place to stop.

Avoid hard braking or sharp steering. If a front tire fails, the vehicle may tend to pull in the direction of the failed tire, so you should maintain a firm grip on the steering wheel to control your direction. See [“Punctured tires”, page 7-16](#).



Hazardous road conditions

Because the SOLO has a single, centered rear wheel, “straddling” obstacles (such as potholes) with the front wheels increases the likelihood that the rear wheel will encounter the obstacle. Observe road conditions carefully while driving and practice safe avoidance maneuvers.

Your SOLO is more likely than a 4-wheel vehicle to lose control on slippery surfaces. Do not operate your SOLO on snowy or icy roads. When driving on gravel, dirt, or sand-covered roads, use extreme caution and reduce your speed, particularly for curves. These surfaces do not provide as much traction as paved surfaces, and you can lose control.

A layer of water on top of a paved surface (e.g. a puddle or flowing water on the road) can cause hydroplaning. As with other vehicles (particularly those with a single rear wheel), your SOLO can hydroplane if you drive too fast over water that has accumulated on the road.

When hydroplaning occurs, one or more wheels rise up on a layer of water, losing contact with the road. If this happens to the rear wheel, you may feel it slide sideways.

Hydroplaning wheels do not have the traction necessary to control the vehicle; you can lose control and spin out. Avoid large water puddles or water streams, and slow down or pull off the road during heavy rains. If you must pass through water, slow down as much as possible before you reach it. After

passing through water, test your brakes. Apply them several times if necessary to allow friction to dry the brake pads. Properly maintained tires reduce the risk of hydroplaning; always maintain recommended tire pressure. See [“Wheels and Tires”, page 7-14.](#)

Never drive your SOLO into bodies of water that would rise above the vehicle’s floor, as you risk submerging the high-voltage batteries. Ensure that the vehicle has sufficient clearance before moving through any body of water. Watch for splashing or spraying when other vehicles drive through water as an indication of depth.



Sudden power loss

If you experience a sudden loss of power while driving, review the instrument cluster display for any system message warnings. See [“System messages”, page 4-11](#). Where possible, respond accordingly to any directions in the warning messages.

If necessary, pull your vehicle over to a safe location. Come to a complete stop and perform the following steps:

1. Apply the Electronic Parking Brake. See [“Electronic Parking Brake \(EPB\)”, page 4-18](#).
2. Shift the vehicle into N (Neutral). See [“Drive Mode Selector”, page 4-7](#).
3. Activate the hazard flashers. See [“Hazard flashers”, page 4-23](#).
4. Have your vehicle towed to an ElectraMeccanica Authorized Repair Facility. See [“Transporting the Vehicle”, page 7-42](#).

Vehicle Load Limits

 **WARNING** The combined weight of the driver, cargo, and any non-factory-installed equipment must never exceed 287 lb (130 kg). Do not load the vehicle any heavier than the Gross Vehicle Weight Rating (GVWR), or either the maximum front or rear Gross Axle Weight Rating (GAWR). Overloading can cause systems to fail and change the way the vehicle handles. This could cause loss of control and lead to a collision. Overloading can also reduce stopping distance, damage the tires, shorten the life of the vehicle, and void the warranty.

It is very important to know how much weight your vehicle can carry. This weight is called the Gross Vehicle Weight Rating (GVWR), which is the combined total weight of the vehicle, the occupant, and all cargo and non-factory-installed options.



General Information

MFD BY: CHONGQING ZONGSHEN AUTOMOBILE INDUSTRY CO. LTD. DATE OF MFG: GVWR: 933 KG
 FOR: ELECTRAMECANICA VEHICLES CORP. MM/YY (2056 LB)

FRONT GAWR	WITH TIRES	RIMS AT	COLD
499 KG (1100 LB)	135/70R15 70T	15X4.5J	228 KPA (33 PSI)
REAR GAWR	WITH TIRES	RIMS AT	COLD
444 KG (978 LB)	215/40R16 86V	16X7.0J	234 KPA (34 PSI)

THE COMBINED WEIGHT OF OCCUPANT AND CARGO SHOULD NEVER EXCEED 130KG (287LB)

MAXIMUM CARGO CAPACITY: REAR 25 KG (55 LB)

THIS VEHICLE CONFORMS TO ALL APPLICABLE FEDERAL MOTOR VEHICLE SAFETY STANDARDS
 IN EFFECT ON THE DATE OF MANUFACTURE SHOWN ABOVE.

VIN: XXXXXXXXXXXXXXXXX

TYPE: MOTORCYCLE

2301-1000951 REV 05

The Tire and Loading Information label shows how much weight the vehicle can properly carry, along with tire specifications.

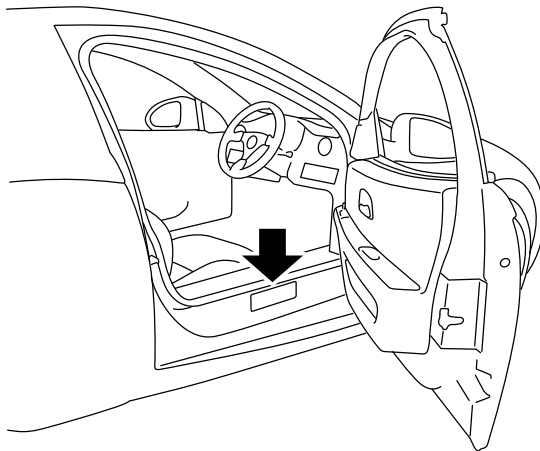

The Tire and Loading Information label is visible when the right door is open.

GVWR	2056 lb	933 kg
Front GAWR	1100 lb	499 kg
Rear GAWR	978 lb	444 kg
Rear Cargo Capacity	55 lb	25 kg



Pre-Drive Inspections

⚠️ WARNING Failure to perform the recommended pre-drive inspections could result in component failure while driving, which could result in serious injury or death. Always perform the pre-drive inspections before each drive. Perform any necessary services before operating if inspections reveal the need for adjustment, replacement, or repair.

To keep your SOLO in safe operating condition, always perform the recommended pre-drive inspections before each use of the vehicle. This is especially important before making a long trip, on first driving the vehicle after an extended period of inactivity or non-use, and when removing the vehicle from storage.

You must be familiar with all instruments and controls in order to perform the pre-drive inspections. See [“Controls and Features”, page 4-1](#).

Pre-Drive Inspection Checklist

General inspections

Turn the key switch to the OFF position before performing the general pre-drive inspections. See [“Key Switch”, page 4-6](#).

If inspection of any item reveals component failure, have the component repaired or replaced before operating the vehicle. See [“Maintenance”, page 7-1](#).

Item	Inspection Procedure	See Page
Tires	Inspect tire condition, pressure, and tread depth.	7-17
Wheels	Inspect for loose, damaged, or missing wheel nuts.	7-18
Underside	Look for fluid deposits underneath the vehicle that might indicate a leak.	-
Fasteners	Inspect entire vehicle for loose, damaged, or missing fasteners.	-
Brake Pedal	Check brake pedal for excessive travel, and verify smooth operation and a full return.	-
Accelerator Pedal	Check accelerator pedal for excessive travel, and verify smooth operation and a full return.	-



Electrical inspections

Turn the key switch to the **ON** position before performing the electrical pre-drive inspections. See [“Key Switch”, page 4-6](#).

If inspection of any item reveals component failure, have the component repaired or replaced before operating the vehicle. See [“Maintenance”, page 7-1](#).

Item	Inspection Procedure	See Page
Battery Level	View the instrument cluster display to check the battery charge.	4-9
Seat	Adjust for proper positioning.	3-1
Seat Belt and Retractor	Inspect the seat belt for damage. Ensure that the belt can be pulled out and retracted smoothly, and that it latches securely.	3-4
Mirrors	Adjust for proper side and rear view.	4-5
Windshield Washer and Wiper	Ensure that the windshield and wiper blade are free of ice. Cycle through each position of the wiper switch and verify that the wiper functions properly. Activate the washer pump and verify that fluid dispenses properly.	4-25
Steering	Check the power steering for smooth operation by turning the steering wheel completely in both directions.	-

Item	Inspection Procedure	See Page
Horn	Press the center of the steering wheel and verify that the horn sounds loudly.	4-4
Front Lights	Verify that the front inner, outer, and center lights illuminate. Switch to high beams. Verify that the high beams indicator illuminates on the instrument cluster display and that headlamp brightness increases.	4-20
Rear Lights	Verify that the taillights illuminate. Apply the brakes and verify that the taillight brightness increases and the center high-mounted brake light illuminates.	4-20
Turn Signals	Verify that the left and right turn signals flash at the front and rear of the vehicle when activated, and that the corresponding arrow indicator flashes on the instrument cluster display.	4-20
Hazard Flashers	Press the hazard flashers switch. Verify that all four turn signals flash, as well as both arrow indicators on the instrument cluster display.	4-20
Electronic Parking Brake (EPB)	Verify that the vehicle does not roll when the EPB is engaged, and that the indicator light illuminates on the instrument cluster display.	4-18

Correct Seating Position

WARNING Use the seat, head restraint, and seat belt correctly for proper protection in the event of a collision, and to ensure that you can see properly and operate controls. Improper adjustment and use can increase the risk of losing control and collision, and increase your risk of death or injury in a collision.

WARNING Failure to adjust the seat backrest correctly could increase the chance that you will suffer a neck/spinal injury in a sudden stop or a collision.

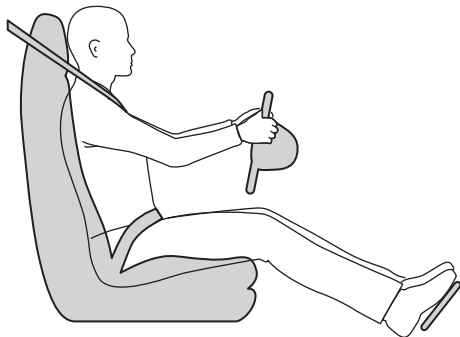

- Select a seat position that allows you to wear the seat belt correctly.
- Sit in an upright position, with both feet on the floor and the seat back reclined no more than 30 degrees.
- Position the seat so that you are able to drive the vehicle safely. You should be able to fully depress the brake and accelerator pedals. Your arms should be slightly bent when holding the steering wheel.
- The head restraint system is integrated with the seat backrest and cannot be adjusted separately. The seat backrest should be adjusted so that the head restraint portion is as close to the back of your head as possible.
- Position the seat belt so that it is midway between your neck and your shoulder. Fit the strap tightly across your hips — not across your stomach.



Seat Adjustment

WARNING Do not adjust any part of the seat while the vehicle is in motion. Vehicle movement may cause the seat to shift suddenly, potentially causing injury or loss of control.

The seat has two controls that are used to adjust:

- Seat forward/rearward position
- Seat backrest angle

Seat forward/rearward position

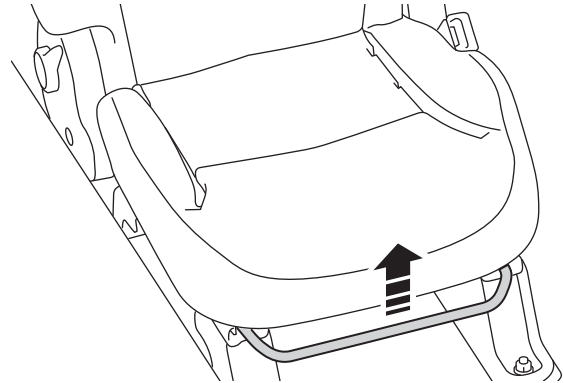

1. With the vehicle parked, lift the bar at the front of the seat cushion to unlock it.
2. Move the seat forward or rearward until it is properly positioned. See [“Correct Seating Position”, page 3-1](#).
3. When the seat is positioned correctly, release the bar.
4. Try to move the seat back and forth to ensure it is locked in place.

Seat backrest angle

WARNING If the seat backrest is not securely locked in position, it could move forward in a sudden stop or collision, causing injury to the seated person. Always push and pull on the seat backrest to ensure it is locked.

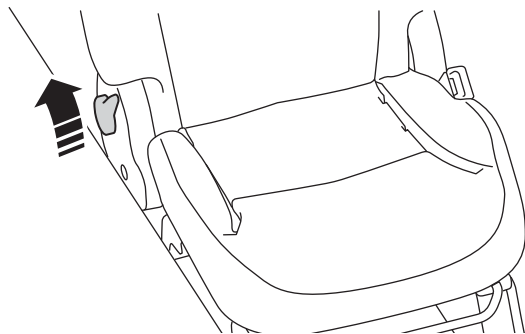

1. Pull back on the lever.
2. Adjust the angle of the backrest so that the head restraint portion is as close to the back of your head as possible.
3. Release the lever to lock the backrest in place.
4. Push and pull on the backrest to ensure it is locked.



Using the Seat Belt

⚠️ WARNING The seat belt should be worn for every trip, no matter how short. Failure to do so greatly increases the risk of death or serious injury in the event of a collision.

The seat belt reduces your risk of injury from interior impacts, the effects of whiplash, or being thrown from the vehicle. Wearing a seat belt is required by law in most jurisdictions.

The seat is equipped with a three-point inertia reel seat belt.

Whenever your vehicle experiences hard acceleration, braking, cornering, or a collision, the belt reel automatically locks, preventing the movement of the occupant. The reel may also lock when driving on steep hills or slopes.

During normal driving conditions, the belt reel allows you freedom of movement.

Seat Belt Safety

⚠️ WARNING Ensure that the seat belt is worn correctly. A seat belt worn improperly increases the risk of death or serious injury in the event of a collision.

⚠️ WARNING Seat belts are designed to bear upon the bony structure of the body, and should be worn low across the pelvis, over the shoulder and across the

chest. Avoid wearing the lap section of the belt across the abdominal area.

⚠️ WARNING Always adjust the belt to remove slack. Seat belts worn too loosely can result in injuries because they allow excessive forward movement in a collision.

⚠️ WARNING Do not wear the seat belt over hard, fragile or sharp items in clothing, such as pens, keys, eyeglasses, etc. In an impact, the pressure from the seat belt on such items can cause them to break, which in turn may cause serious injury.

⚠️ WARNING Never place anything between you and the seat belt. This reduces the protection provided by the belt and may cause injury in a collision.

⚠️ WARNING The seat belt should not be worn with any part of the strap twisted.

⚠️ WARNING The belt assembly must only be used by one occupant; it is dangerous to put a belt around a child being carried on the occupant's lap.

⚠️ WARNING No modifications or additions should be made that prevent the seat belt mechanism from taking up slack, or that prevent the seat belt being adjusted to remove slack. A slack belt greatly reduces the level of occupant protection.

Fastening and Releasing the Seat Belt

Fastening the belt

1. Make sure that your seat is correctly positioned. See [“Seat”, page 3-1](#).

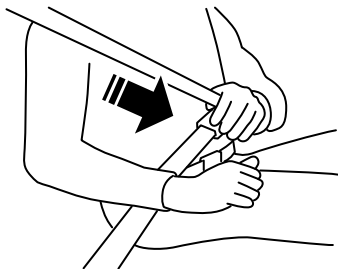

2. Pick up the latch plate and pull the belt smoothly towards the buckle, ensuring that the belt lays flat across your pelvis, chest, and the midpoint of your collar bone between the neck and shoulder. Do not let the belt get twisted.

Note: *The belt may lock if you pull it too quickly. If this happens, let the belt retract slightly to unlock it, then pull the belt more slowly.*

Note: *If the webbing locks in the latch plate before it reaches the buckle, tilt the latch plate to unlock it.*

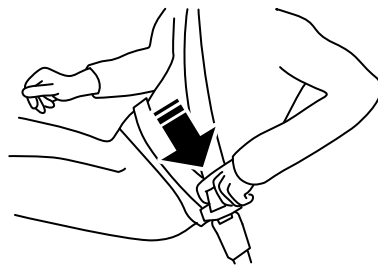

3. Push the latch plate into the buckle until it clicks. Pull up on the latch plate to ensure it is secure. Position the release button on the buckle so that the seat belt can be quickly unbuckled if necessary.

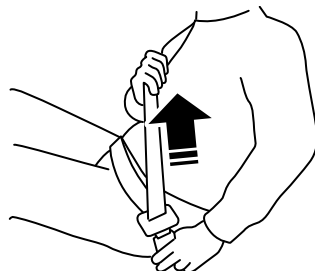

4. To tighten the lap portion of the belt, pull up on the shoulder belt.



Releasing the belt

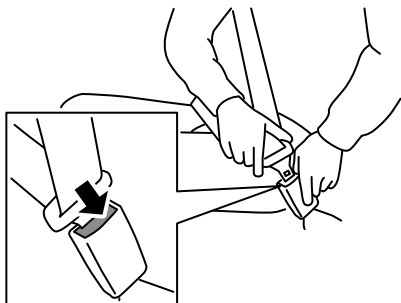

To unlatch the belt, push the release button on the buckle. The belt should retract to its stowed position.

Always allow the seat belt to retract slowly. If the seat belt retracts quickly to the stowed position, the webbing may jam in the retractor. If this happens, firmly pull the seat belt straight out to unlock the webbing, and then release it. If the webbing is still jammed in the retractor, contact your ElectraMeccanica Authorized Repair Facility.

CAUTION Before closing a door, make sure the seat belt is out of the way. If a door is closed on the seat belt, damage could occur to both the seat belt and the vehicle.

Wearing the Seat Belt when Pregnant

WARNING A pregnant woman should always wear a seat belt to protect herself and her unborn child.

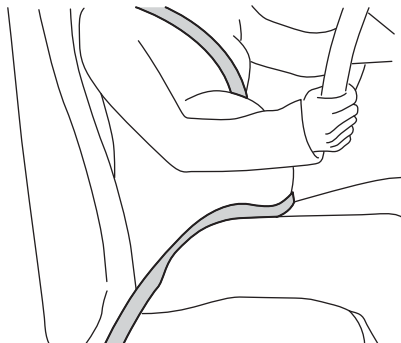

You should wear the lap portion of the belt as low as possible across your hips, not your waist. Position the diagonal part of the belt between the breasts and to the side of your abdomen.

The best way to protect the unborn child is to protect the mother. When a seat belt is worn properly, it is more likely that the unborn child will not be hurt in a collision.

If you have any concerns about wearing seat belts during pregnancy, contact your doctor.



Caring for the Seat Belt

Periodically check the seat belt indicator, seat belt, buckle, latch plate, retractor, and seat belt anchorages to make sure they are all in working order. Look for any other loose or damaged seat belt system parts that might keep the system from performing properly. Replace the seat belt if you notice any damage to the belt webbing, fittings, retractor mechanisms or buckles.

Check the operation of your seat belt as follows:

1. Fasten the seat belt and give the webbing nearest the buckle a quick pull. The buckle should remain securely locked.
2. Unfasten the seat belt and unreel the webbing to its limit. Check that there are no snags while unreeling and visually check the webbing for wear. Allow the webbing to retract. The retraction should be smooth and complete.
3. With the webbing half unreeled, hold the tongue plate and pull sharply forward. The mechanism must lock automatically and prevent further unreeling.

If your seat belt fails any of these tests, contact your ElectraMeccanica Authorized Repair Facility immediately.

Cleaning



WARNING

Do not allow any water, cleaners, or fabric from clothes to enter the seat belt mechanism. Any substance which enters the mechanism may affect the performance of the seat belt in an impact.

Extend the seat belt and clean with fresh, warm, soapy water only. Do not use any type of detergent or chemical cleaning agent. Allow the belts to dry naturally while extended, preferably away from direct sunlight.

The seat belt mechanism should be kept dry and free of dust or debris. Exterior hard surfaces may be lightly cleaned with mild soap and water. Ensure there is no excessive dust or debris in the mechanism. If dust or debris exists in the system, please contact your ElectraMeccanica Authorized Repair Facility. Parts may need to be replaced to ensure proper functionality of the system.



A series of 15 horizontal dashed lines for writing.



This page intentionally left blank.



Controls Overview

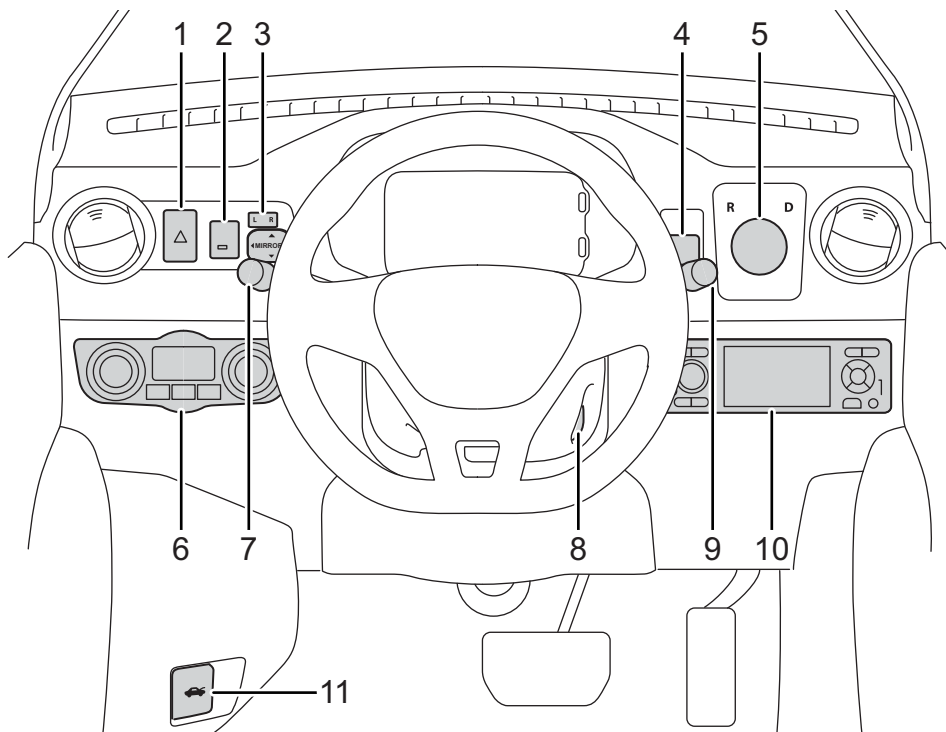



1. Hazard warning lights switch ([page 4-23](#))
2. Trunk release ([page 4-34](#))
3. Mirror adjustment controls ([page 4-5](#))
4. Electronic Parking Brake switch ([page 4-18](#))
5. Drive Mode Selector ([page 4-7](#))
6. Climate controls ([page 4-29](#))
7. Turn signals/high-beam headlight control ([page 4-22](#))
8. Key switch ([page 4-6](#))
9. Windshield wiper/washer control ([page 4-25](#))
10. Radio
Refer to the separate Infotainment manual supplied with the vehicle.
11. Hood release ([page 4-28](#))





Steering Wheel Position

WARNING Never adjust the steering wheel position while the vehicle is in motion. Doing so will reduce control of the vehicle, and may cause unpredictable steering movements.

The lever underneath the steering column is the tilt wheel lever. If necessary, you can raise the steering wheel to the highest level to give your legs more room when you enter and exit the vehicle.

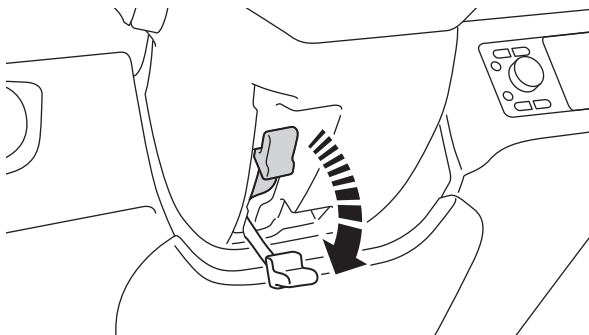

To tilt the wheel, hold the wheel and pull the lever. Move the wheel to a comfortable position and engage the lever to lock the wheel in place.

Horn

WARNING The SOLO runs quietly. Watch for pedestrians and other road users who may not be aware of your presence, and use the horn to alert them when needed.

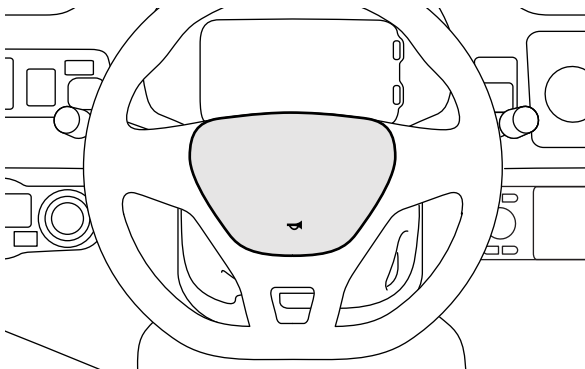

With the key switch in the ON position, press the center of the steering wheel to sound the horn.



Exterior Power Mirrors

WARNING Depending upon the type of mirror glass fitted to your vehicle, distances may be difficult to judge accurately. Objects viewed in the mirror may be closer than they appear.

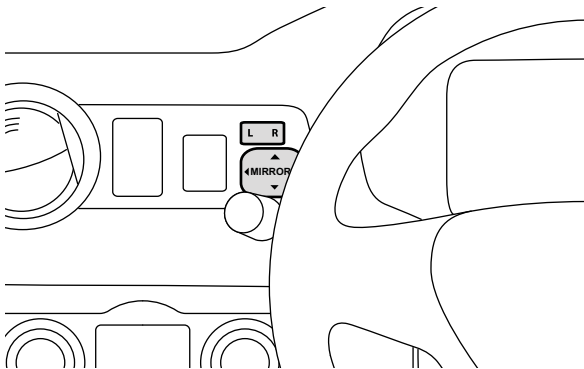

The controls for the exterior power mirrors are located on the dashboard, to the left of the steering column. You can adjust the mirror position as follows:

1. Press L or R on the selection switch to choose the left- or right-side mirror.
2. To set the desired mirror position, press up, down, left, or right on the **MIRROR** button to adjust accordingly.

Adjust both mirrors while sitting in a normal driving position.

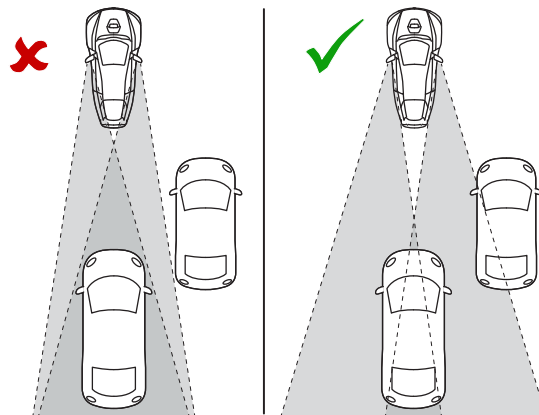

The ideal adjustment should allow you to see a vehicle directly behind you in both mirrors, but with minimal overlap of that image, as illustrated. This allows you to see more of the lanes to either side of you and minimizes blind spots.

Note: Because the body of the SOLO is tapered in the rear, little to none of the sides of the vehicle should be visible in the mirrors when sitting in a normal driving position.

When not adjusting the mirrors, keep the mirror selection switch in the center position to prevent accidental adjustment while driving.



Key Switch

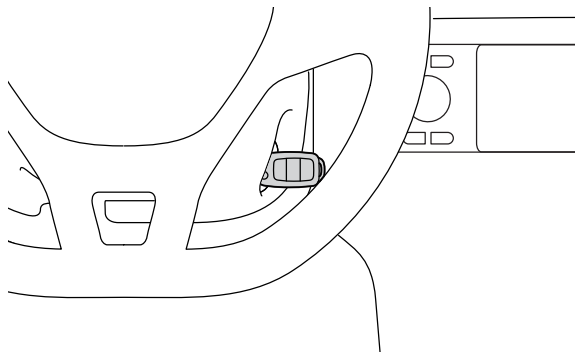

This is a four-position switch that is located on the right of the steering column and is operated by inserting the key. The switch positions are as follows:

1. OFF
2. ACC
3. ON
4. START

Note: Do not move the steering wheel while cycling the key switch from OFF to ON, as this can result in a fault. If the fault occurs, see [“EPS and Fault indicators on key-on”, page 4-16.](#)

OFF position

Used to turn the vehicle OFF, disabling the electrical system. Take the key from the vehicle when parked to prevent theft.

Note: If a door is opened and the key is in the key switch while in the OFF position, an audible warning will activate to remind the operator to remove the key.

Note: The steering column will lock when the key is in the OFF position, and will not be able to be turned.

ACC position

This position provides power to the windows and radio.

Note: In this position, the 12V battery is not being charged.

ON position

Used to operate the vehicle. Steering column lock disengages and all normal operating functions are turned on, including:

- All running lights
- Instrument cluster display

START position

When the key switch is turned to the START position, the drive system will power up if the following conditions are met:

- The brake pedal is pressed
- The Drive Mode Selector is set to N (Neutral)

See [“Starting the Vehicle”, page 6-3.](#)



Drive Mode Selector

CAUTION Shifting to R (Reverse) or D (Drive) when the vehicle is moving in the opposite direction could damage the drive system. These repairs would not be covered by the vehicle warranty. Only shift into R or D when the vehicle is stationary and the brake is applied.

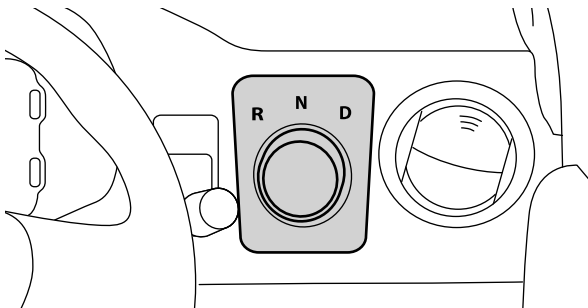

This is a three-position dial, used to set the desired direction of the vehicle.

The dial positions are as follows:

- R - Reverse

Use this position to back up.

Note: When R is selected, the instrument cluster displays the view from the rear view camera. See [“Back-Up Camera”, page 4-17.](#)

- N - Neutral

In this position, the drive system does not drive the rear wheel.

- D - Drive

Use this position to go forward.

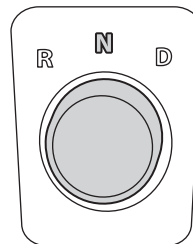

The current position is illuminated on the dial, and is also indicated on the instrument cluster display. See [“Instrument Cluster Display”, page 4-9.](#)



Abnormal shift condition

In the event that the drive mode is shifted while the vehicle is traveling at a speed higher than 2 mph (3 km/h), the following will occur:

- The vehicle will shift into N (Neutral) and remain in N (Neutral) unless the driver selects the original gear that was in use
- An audible alert will sound

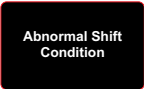

Abnormal Shift
Condition

- The “Abnormal Shift Condition” system message will display on the instrument cluster display

Note: *The brake pedal does not need to be pressed to shift back into the original gear that was selected while the vehicle is still moving.*

To change the direction you are traveling in, see [“Starting and Drive Selection”, page 4-6.](#)





Instrument Cluster Display

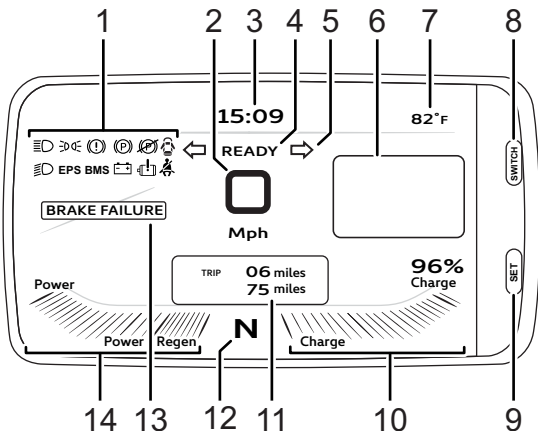

4. Drive status message ([page 4-10](#))
5. Turn signal/hazard indicators ([page 4-10](#))
6. System messages ([page 4-11](#))
7. External ambient temperature ([page 4-11](#))
8. SWITCH button ([page 4-11](#))
9. SET button ([page 4-12](#))
10. High-voltage battery state of charge ([page 4-11](#))
11. Trip meter/odometer ([page 4-12](#))
12. Drive mode indicator ([page 4-10](#))
13. Brake failure warning ([page 4-10](#))
14. Power/regen gauge ([page 4-13](#))

Note: To reduce power consumption, the instrument cluster display will automatically turn off after a door or the trunk have been opened for an extended period of time. Cycle the key switch to wake the system. See [“Key Switch”, page 4-6](#).

1. Indicator and warning lights ([page 4-10](#))
2. Speedometer ([page 4-10](#))
3. Clock ([page 4-12](#))



Indicator and warning lights

These lights may illuminate to advise you of a specific vehicle status or condition. See [“Indicator Lights”, page 4-14](#) and [“Warning Lights”, page 4-15](#).

Speedometer

The speedometer is a digital display in either miles per hour (mph) or kilometers per hour (km/h), indicating the current speed of the vehicle.

Drive status message

READY READY displays when all starting conditions have been met and the vehicle can be driven. See [“Starting the Vehicle”, page 6-3](#).

Drive mode indicator

This indicator reflects the position of the Drive Mode Selector dial. See [“Drive Mode Selector”, page 4-7](#).

Turn signal/hazard indicators



When the exterior light control lever is moved to the left or right position, the corresponding front and rear turn signals flash. As the lever is activated, the corresponding turn signal indicator on the instrument cluster display illuminates. See [“Turn signals”, page 4-22](#).

Always signal your turns and other maneuvers as required by law.

When the hazard flashers are activated, both turn signal indicators on the instrument cluster display will flash. See [“Hazard flashers”, page 4-23](#).

Brake failure warning

WARNING If the brake failure warning illuminates while driving, slow down and pull off the road as soon as it is safe to do so.

BRAKE FAILURE The brake failure warning will display if an issue is detected with the hydraulic portion of the braking system.

If this warning is still displayed after safely pulling over and stopping the vehicle, check the warning lights on the instrument cluster display. If the Electronic Parking Brake (EPB) or brake warning indicators are illuminated, follow the applicable instructions and cautions. See [“Warning Lights”, page 4-15](#).



System messages



CAUTION Always heed the instructions and warnings displayed in system messages.

Failure to do so could cause damage to the vehicle, which would not be covered under the warranty.

Specific instructions or warnings will be displayed here. Some examples:



Limited Power

The Limited Power message will display to indicate that the vehicle has taken action to reduce electrical power consumption. Driving performance, such as vehicle acceleration behavior, may also be altered to reduce power consumption. If this message appears, charge the vehicle as soon as possible. See [“Charging the Vehicle”, page 5-3](#). If this message persists after charging, contact an ElectraMeccanica Authorized Service Provider.

Note: The limited power message will also be displayed if the vehicle speed exceeds 82 mph (132 km/h). The message will turn off when the speed decreases to 80 mph (128 km/h). The message will also flash ON when torque limiting traction control is activated.



Caution

The Caution message will display when the vehicle's systems detect the ambient temperature of 39°F (4°C), indicating possible slippery road conditions. If this message appears, use caution and reduce your driving speed. See [“Hazardous road conditions”, page 2-2](#).

High-voltage battery state of charge

This displays the percentage of charge remaining in the high-voltage battery pack.

Note: When the charge level decreases to less than 19% the display background will turn red. Charge the battery pack as soon as possible. See [“Charging the Vehicle”, page 5-3](#).

External ambient temperature

Displays the current exterior temperature in Fahrenheit (F).

SWITCH button

Press the SWITCH button to change between eight different display illumination levels.



Clock

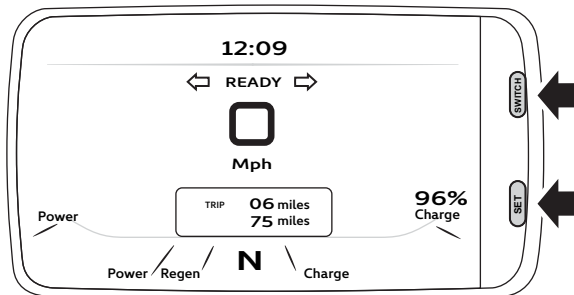

To adjust the time:

1. Press and hold the **SWITCH** button until the colon in the center of the clock starts to flash (approximately 5 seconds).
2. Press the **SWITCH** button to adjust the hours and the **SET** button to adjust the minutes.
3. The time will save when the colon in the center of the time stops blinking after 10 secs.

Trip meter/odometer

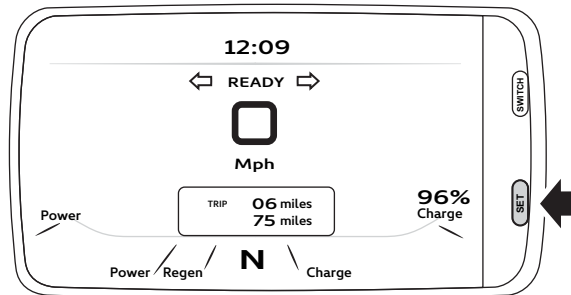

To reset the trip meter, press the **SET** button until the current trip distance (top number) resets to zero (approximately 5 seconds).

Note: Holding SET will not reset the odometer (bottom number).



Power/Regen gauge

This gauge indicates the current amount of power in kilowatts (kW) that the vehicle is using or generating.

The bars on the Regen gauge indicate the current amount of energy being fed back into the battery through regenerative braking. See [“Regenerative Braking”, page 6-6](#).

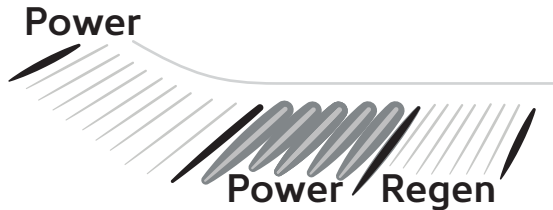

The bars on the Power gauge indicate the amount of power being used by the vehicle. The harder you accelerate, the higher the gauge will read.

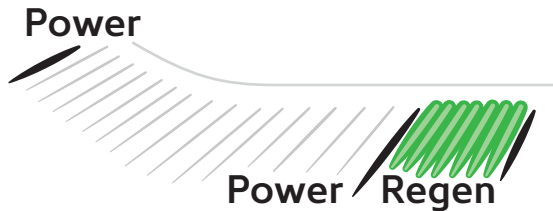



Indicator Lights

Daytime running lights indicator



This indicator illuminates when the Daytime Running Lights are activated. See [“Daytime running lights”, page 4-21.](#)

Low-beam headlights indicator



This indicator illuminates when the low-beam headlights are activated. See [“Auxiliary Low beams”, page 4-21.](#)

High-beam headlights indicator



This indicator illuminates when the high-beam headlights are activated. See [“High beams”, page 4-22.](#)

Door ajar indicator



This indicator illuminates when a door or the trunk is not closed. Before driving, check that both doors and the trunk are properly closed.

Note: If the vehicle is keyed ON, an alert will sound until both doors and the trunk are closed.

Fasten seat belt indicator



This indicator illuminates when the seat belt is not buckled. See [“Seat Belt”, page 3-4.](#)

Note: If the seat belt is not buckled when the vehicle is keyed ON, an alert will sound for approximately 8 seconds.

Electronic Parking Brake (EPB) indicator



This indicator illuminates when the EPB is applied. See [“Electronic Parking Brake \(EPB\)”, page 4-18.](#)



Warning Lights

Brake warning indicators

 **WARNING** If a brake warning indicator illuminates while driving, slow down and pull off the road as soon as it is safe to do so.

The vehicle brake system consists of two hydraulic circuits. If one circuit is not working, the remaining circuit will still work to stop the vehicle. For normal braking performance, both circuits need to be working.

The brake warning indicators illuminate briefly when the key switch is turned to START, indicating that they are working. If an indicator illuminates and remains illuminated, there is a brake problem.

 The red brake warning indicator illuminates when the system detects a low brake fluid level. Check the brake fluid and fill as needed. See [“Brake Fluid”](#), page 7-8.

 The yellow brake warning indicator illuminates when the system detects a brake problem. Have the vehicle transported to an ElectraMeccanica Authorized Service Provider for service. See [“Vehicle Recovery”](#), page 7-42.

Electronic Parking Brake (EPB) warning indicator



If the EPB warning indicator illuminates continuously or flashes, there is a problem with the EPB. Have the EPB system inspected immediately by an ElectraMeccanica Authorized Service Provider.

12V battery warning indicator



The 12V battery warning indicator illuminates briefly when the key switch is turned to START, indicating that it is working. If the indicator stays on or illuminates while driving, this indicates that the 12V power supply of the vehicle is lower than the acceptable range.

If this indicator illuminates while you are driving, slow down and pull off the road as soon as it is safe to do so. Have the vehicle transported to a facility where you can charge the 12V battery. See [“Charging the 12V Battery”](#), page 7-31.

If the 12V battery warning indicator remains illuminated after charging the 12V battery, contact your ElectraMeccanica Authorized Service Provider.

Fault indicator



If this indicator illuminates, a fault has been detected. Malfunctions are often detected by the system before any problem is noticeable. Being aware of the indicator and seeking service promptly when it illuminates may prevent vehicle damage.



The SOLO is programmed so that if a functional error occurs with the vehicle, it will go into Limited Power mode. In this mode, the performance of the vehicle is significantly reduced, but it is still drivable.

If this indicator illuminates, contact your ElectraMeccanica Authorized Service Provider.

Electric Power Steering (EPS) warning indicator

EPS

The EPS indicator illuminates briefly when the key switch is turned to START, indicating that the EPS system is working. If the indicator illuminates and remains illuminated, there is a problem with the EPS system; have it inspected immediately by an ElectraMeccanica Authorized Service Provider.

Battery Management System (BMS) warning indicator

BMS

The BMS manages and monitors the vehicle's batteries to track their energy status, control their environment, and ensure they operate safely. The BMS indicator illuminates briefly when the key switch is turned to START, indicating that the BMS system is working. If the indicator illuminates and remains illuminated, there is a problem with the BMS system and the vehicle will be in Limited Power mode. In this mode, the performance of the vehicle is significantly reduced, but it is still drivable. Have the vehicle inspected immediately by an ElectraMeccanica Authorized Service Provider.

Warning Light Combinations

EPS and Fault indicators on key-on

If the steering wheel is moved while turning the key switch to the ON position, the Fault and EPS warning indicators may illuminate on the instrument cluster display. If this occurs, turn the key switch to OFF, then cycle to ON without touching the steering wheel. See [“Key Switch”, page 4-6](#).

If this action does not clear both warning indicators, it can mean there is a problem with the vehicle. Do not drive the vehicle, and contact your ElectraMeccanica Authorized Service Provider.

Electronic Parking Brake (EPB) indicator and EPB warning

If the EPB indicator and the EPB warning indicator flash simultaneously, this indicates that the EPB connector has been disconnected from the parking brake. In this instance, the two indicators will continue to flash for approximately 15 seconds after the key switch has been turned to OFF. Do not drive the vehicle, and contact your ElectraMeccanica Authorized Service Provider.



Back-Up Camera

WARNING Do not rely solely upon the back-up camera when driving in R (Reverse). Check all mirrors visually before backing up to ensure your path is clear of pedestrians and obstacles.

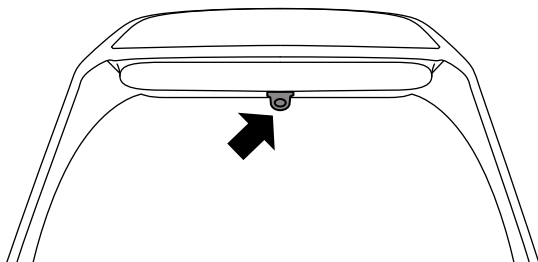

Your SOLO utilizes a camera mounted to the trunk cover, giving you a live video on the instrument cluster display of what is behind the vehicle while reversing. See [“Instrument Cluster Display”, page 4-9.](#)

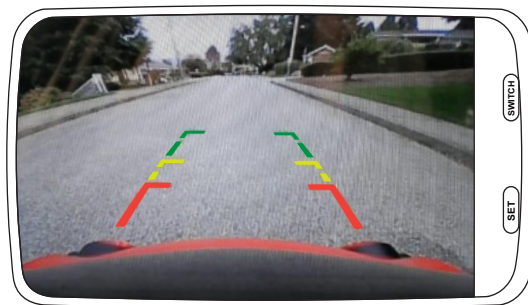

When the Drive Mode Selector is in R (Reverse), the instrument cluster display switches to the rear camera view.

If your video display is cloudy or otherwise obscured, the camera lens may require cleaning. See [“Cleaning the back-up camera”, page 7-38.](#)



Electronic Parking Brake (EPB)

WARNING When parking on a hill or slope, ensure that you set your wheels in accordance with the instructions in [“Parking on hills and slopes”, page 6-7](#) before applying the EPB.

This vehicle features an EPB, which has both manual and automatic functions.

 When the EPB is engaged, the EPB indicator will illuminate on the instrument cluster display. See [“Instrument Cluster Display”, page 4-9](#).

Note: The EPB can only be engaged or disengaged manually when the vehicle's speed is less than 2 mph (3 km/h) and the key switch is ON. See [“Key Switch”, page 4-6](#).

Note: The EPB can be engaged in any Drive Mode Selector position. See [“Drive Mode Selector”, page 4-7](#).

Note: Charge the 12V battery if it lacks sufficient charge to power the EPB. See [“Charging the 12V battery”, page 7-33](#).

Automatic EPB operation

The EPB will engage automatically when the vehicle's speed is less than 2 mph (3 km/h) and the key switch is turned to the OFF position. When the vehicle is in READY mode, the EPB will automatically engage in any drive mode when the seat belt is not fastened, a door is opened, and the brake pedal is not pressed.

The EPB will disengage automatically when the vehicle is in READY mode, the Drive Mode Selector is in D (Drive) or R (Reverse), and the accelerator is pressed.

Note: If the vehicle is stopped on a slope when the EPB is engaged, the EPB will automatically adjust when to release the brake according to the level of the slope to prevent rolling.

Manual EPB functions

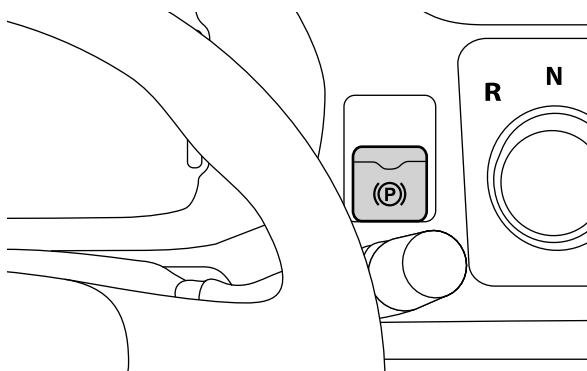

The EPB is manually controlled by a rocker switch to the right of the steering wheel. After this switch is pushed or pulled, it will return to its neutral position.



- To engage the EPB: Once the vehicle is moving at less than 2 mph (3 km/h), pull the EPB switch.
- To disengage the EPB in READY mode: Press the brake pedal and then push in the EPB switch.
- To disengage the EPB when not in READY mode: Press the brake pedal and then push and hold the EPB switch for 30 seconds.

Note: *If the 30-second long push of the EPB switch is interrupted, you must repeat it for the full 30 seconds.*



While holding the EPB switch, the “Start Vehicle” system message will appear on the instrument cluster display. See [“System messages”, page 4-11.](#)

Note: *To hold the vehicle on a slope, the EPB can be manually engaged to prevent the vehicle rolling as your foot moves from the brake pedal to the accelerator pedal. See [“Stopping on hills and slopes”, page 6-5.](#)*

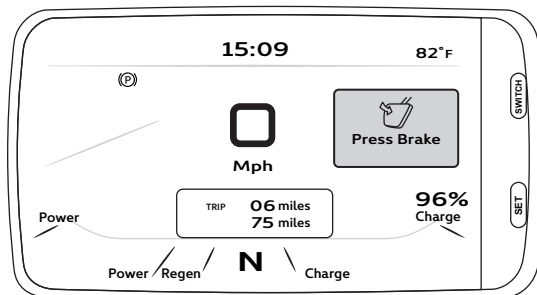

Note: *If the brake pedal is not pressed when the EPB switch is pressed, you will be prompted to do so by a system message on the instrument cluster display.*



Exterior Lights

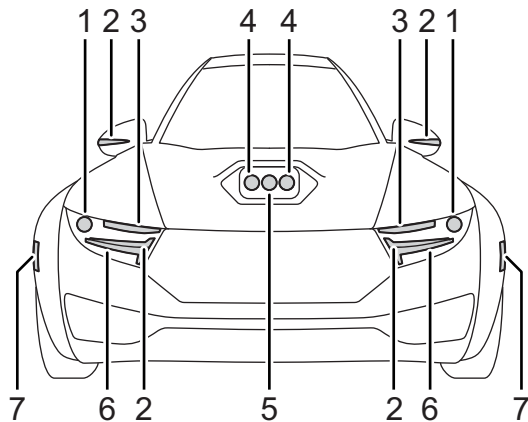

1. Auxiliary low beams ([page 4-21](#))
2. Turn signals ([page 4-22](#))
3. Daytime Running Lights ([page 4-21](#))
4. High beams ([page 4-22](#))
5. Low beams ([page 4-21](#))
6. Position lights ([page 4-21](#))
7. Side marker lights ([page 4-21](#))

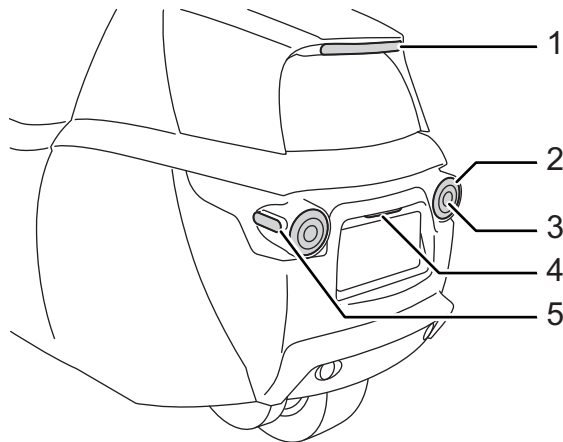

1. Center high-mounted brake light
2. Position lights, turn signals, brake lights
3. Reverse lights
4. License plate lights
5. Side marker lights



Exterior Light Control

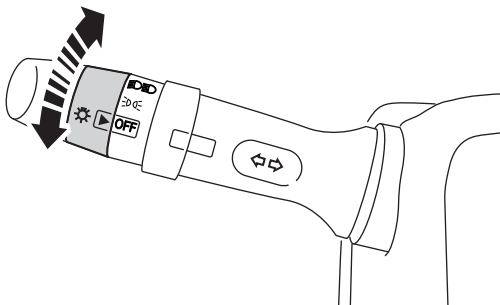

The exterior light control lever is located on the left side of the steering column, just behind the steering wheel.

The lever has a collar that can be turned to select different exterior light configurations.

License plate light, Position lights, and Side marker lights

These lights will turn ON at the key ON position and will remain ON in all the collar switch positions including the OFF position. The position lights and side marker lights make it easier for others to see your vehicle in low-visibility conditions (e.g. fog and rain).



An indicator will illuminate on the instrument cluster display when the license plate light, position lights, and side marker lights are on. See [“Instrument Cluster Display”, page 4-9](#).

Low beams

The low beam lamp will turn ON at the key ON position. It will remain ON in all the collar switch positions including the OFF position and high beam flash position. The low beam lamp only turns off when the high beam lamps are selected.

Daytime running lights

Daytime running lights can improve the visibility of your vehicle during the day. The lights are activated when the collar is in the middle position.

Auxiliary Low beams

The Auxiliary Low beam lamps will turn ON at the key ON position. They remain ON in all the collar switch positions including the OFF position and high beam flash position. The auxiliary low beam lamps only turn off when the high beam lamps are selected.



An indicator will illuminate on the instrument cluster display when the collar switch is in the headlight position and the auxiliary low beams are ON. See [“Instrument Cluster Display”, page 4-9](#).



High beams

The high-beam headlights can be activated manually when needed to improve visibility in low-light conditions.

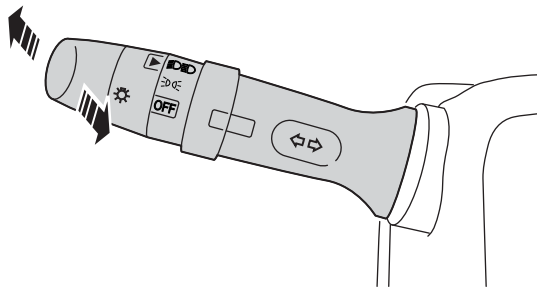

When the collar switch is in the **head light** position, push the lever away from you to activate the high beams. Pull the lever towards you to return to low beams.



An indicator will illuminate on the instrument cluster display when the high beams are on. See [“Instrument Cluster Display”, page 4-9](#).

To flash the high beams, pull the lever towards you. It will return to the neutral (low beam) position when released. The flashing feature can be used when the collar is in any of the positions on the lever.

Turn signals

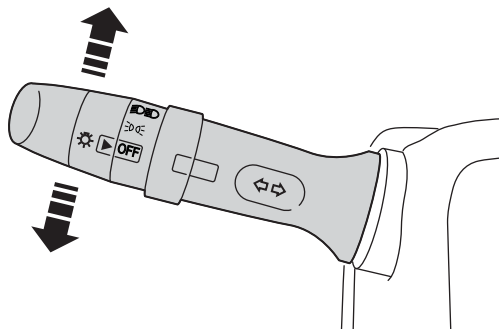

The lever has three positions: Upward (for right), downward (for left), and a neutral position for OFF. The corresponding turn signal lights on the front and rear of the vehicle will flash in the direction indicated by the lever.

To signal a lane change, move the lever up or down to the resistance point and let go to return it to the neutral position. The corresponding turn signal will flash three times.

To signal a turn, move the lever all the way up or down past the resistance point. When the turn is finished, the lever will automatically return to the neutral position.



An arrow on the instrument cluster display will flash in the direction of the lever position. See [“Instrument Cluster Display”](#), [page 4-9](#).

Note: *If an arrow indicator flashes at twice the normal speed, this indicates that the bulb in that turn signal light is out. Contact your ElectraMeccanica Authorized Service Provider.*

Hazard flashers

Activating your hazard flashers warns others that you are in an emergency situation, or stopped or pulled over unexpectedly on the road.

The hazard flashers switch is located on the dashboard, to the left of the steering wheel.

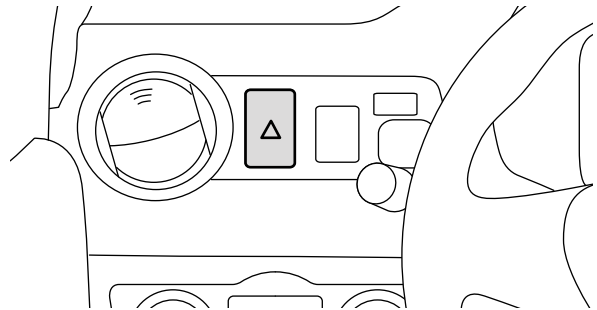

Press the switch to make the front and rear turn signal lights flash on and off. Press the switch again to deactivate.

The hazard flashers will operate with the key switch in any **position**, or if the key is not in the switch. See [“Key Switch”](#), [page 4-6](#).



Interior Lights

Both interior lights automatically illuminate when the doors or the trunk are opened, and turn off when they are closed.

Cabin light

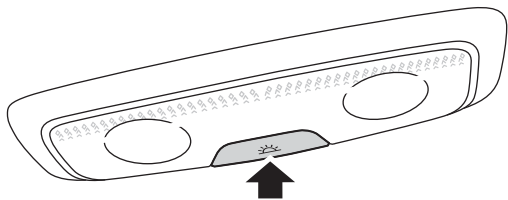

The cabin light is located above the right window. Press the button to turn it on, and press again to turn it off. This light can be used whether or not the vehicle is powered on.

Trunk light

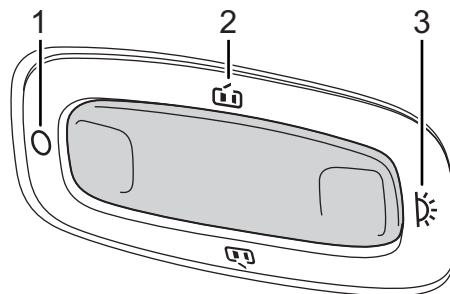

This light is located in the trunk on the right-hand side of the trim, and can be used to manually turn the trunk light to the desired function:

1. Always OFF
2. ON when trunk is open
3. Always ON



Windshield Wiper/Washer Lever

The lever located on the right side of the steering column controls the windshield washer and the wiper.

Note: To prevent damage to the edge of the wiper blade, clear any ice from the windshield before turning on the wiper.

Windshield washer

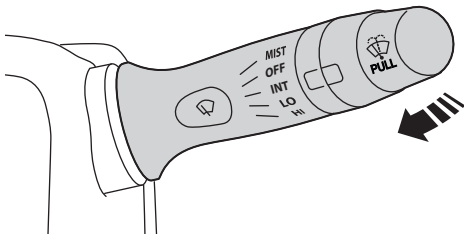

To activate the windshield washer, pull the lever toward you and hold it. The washer fluid sprays for as long as the lever is held, and will trigger the wiper to run on low speed, then wipe one more time after the lever is released.

If no fluid comes out when the lever is pulled, verify that the washer fluid reservoir contains fluid. See [“Washer Fluid”, page 7-10.](#)

Windshield wiper

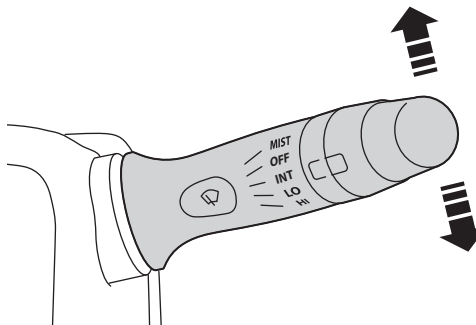

Push the lever up or down to the desired position to activate the wiper.

- **MIST:** Upper position; wiper runs at high speed until you release the lever.
- **OFF:** Neutral lever position; wiper is off.

Note: When switched OFF, the wiper will automatically return to its initial position at the base of the windshield.

- **INT:** Down one position; intermittent speed (wiper operates every few seconds).
- **LO:** Down two positions; wiper runs at low speed.
- **HI:** Down three positions; wiper runs at high speed.



Remote Keyless Entry (RKE) System

WARNING The remote transmitter contains a small battery which, if swallowed, can cause internal burns, severe injury, or death. Keep batteries out of reach of children. Seek medical attention immediately if a battery is swallowed.

The Remote Keyless Entry (RKE) system allows for vehicle entry when the remote transmitter is within range. A decrease in operating range (the distance between the vehicle and the transmitter) could be caused by:

- Weather conditions
- Nearby radio towers
- Structures around the vehicle
- Other vehicles parked next to your vehicle
- Weak transmitter batteries

There is one battery inside each transmitter. The battery should last approximately one year under normal use. When a battery becomes weak, you will notice that the operating range deteriorates and the small LED on the transmitter dims. To replace a battery, see [“Remote Keyless Entry \(RKE\) Transmitter Battery Replacement”, page 7-35.](#)

Remote Transmitter

Note: The remote transmitter functions are disabled when the key switch is NOT in the OFF position. See [“Key Switch”, page 4-6.](#)

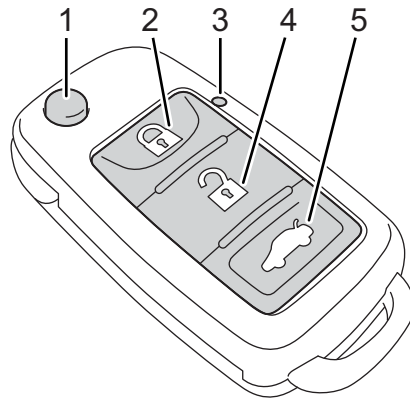

1. Key Blade Release Button
2. Lock Button
3. LED
4. Unlock Button
5. Trunk Release Button



Releasing the key blade

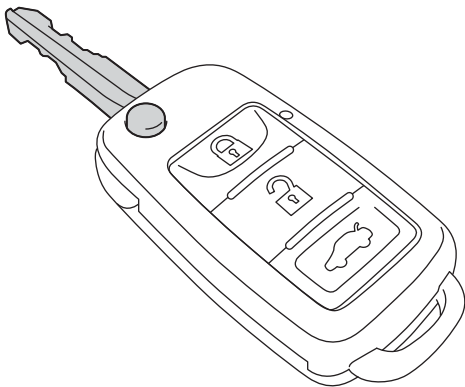

Press the key blade release button, and the key blade will flip out from the transmitter.

To hide the key blade, fold it manually back into the transmitter.

Note: If the vehicle or transmitter have no power, the key blade can be used in the left door to manually unlock that door. Insert the key blade into the door lock, then rotate left (counterclockwise) to unlock.

Locking the vehicle



Exit the vehicle, close both doors, and press the lock button on the transmitter once. The turn signal lights will flash once, indicating that the system has locked both doors.

Note: Locking the vehicle with the transmitter will disable the trunk release button on the dashboard until the vehicle is unlocked by the transmitter. See [“Trunk”, page 4-33](#).

Note: Ensure that both passenger doors and the trunk are closed before pressing the lock button on the transmitter. If either door or the trunk is open when the transmitter’s lock button is pressed, the locks will not activate and the horn will chirp to notify you.

Unlocking the vehicle



Press the unlock button on the transmitter once. The turn signal lights will flash twice and the horn will chirp once, indicating that the system has unlocked both doors.

Trunk release



Press and hold the trunk release button on the transmitter for two seconds to open the trunk. See [“Trunk”, page 4-34](#).

Note: If the vehicle has no power, the trunk can be opened manually. See [“Emergency trunk release”, page 4-34](#).



Hood

CAUTION

Only store the charge cable in its designated space under the hood. Do not store any additional items in this area. This area is not watertight.

Opening the hood

WARNING

Never pull the hood release when the vehicle is moving.

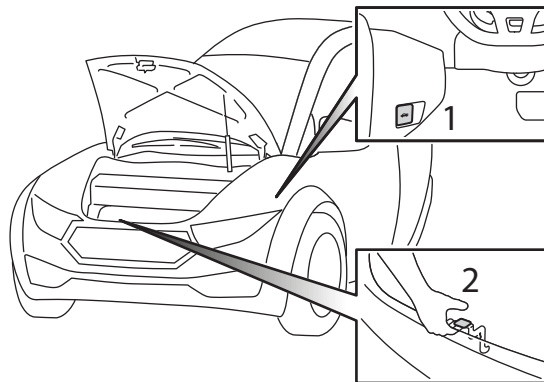

1. Pull the handle (1) located on the side panel under the lower left corner of the dashboard. This will release the primary latch for the hood.
2. Lift the secondary catch release lever (2) under the front lip of the cover and raise the hood.

Closing the hood

Firmly push down on the hood until both the secondary and primary latches are engaged. A audible click will be heard, and visually, the hood-to-grill gap will be minimized.



Climate Controls

The climate controls are located on the dashboard, left of the steering wheel. These controls can be used to adjust the air circulation, temperature, defroster, and fan speed within the vehicle.

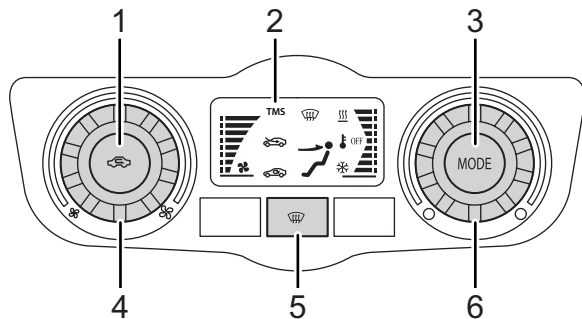

1. Recirculation Button
2. TMS Error Icon
3. Mode Button
4. Fan Speed Dial
5. Defrost Button
6. Temperature Control Dial

Recirculation button

WARNING You should leave the system in fresh air mode under most conditions. Keeping it in recirculation mode can cause the windows to fog up, which can obscure vision and result in a collision.

 To recirculate air within the vehicle, press the recirculation button. When activated, air inside the vehicle will be continuously pushed through the system, and the recirculation indicator will illuminate on the climate control display.

 To draw fresh air from outside the vehicle, press the recirculation button again. The exterior air indicator will illuminate on the climate control display.

Switch to recirculation mode when driving through dusty or smoky conditions, then return to fresh air mode.

The outer air intakes for the climate control system are at the base of the windshield. Keep this area clear of leaves and other debris.

Thermal Management System (TMS) error icon

If the TMS error icon illuminates, this indicates an issue with the Thermal Management System. This system controls the climate within the vehicle, as well as the cooling and heating for the battery system. Contact your ElectraMeccanica Authorized Service Provider for service.



Mode button



Use the mode button to select the direction of air flow through the vents. Each time the mode button is pressed, the climate control display indicates the current direction selected.

Fan speed dial



The fan speed settings range from 0 (off) to 8 (highest speed). Turn the left dial clockwise (right) to increase the fan speed, and counterclockwise (left) to decrease it. The speed setting will illuminate accordingly on the climate control display.

Defrost button



Press the defrost button to override the current climate control settings with the optimal settings to defrost the windshield. The defrost mode:

- Directs air through the defroster outlet at the base of the windshield
- Sets the fan speed and heat settings to maximum
- Sets the recirculation setting to exterior

Press the defrost button again to return to the previously selected settings.

Note: The defrost button will also activate the heated side mirrors.

Temperature control dial

Note: It is not recommended to activate the air conditioning when the ambient temperature is less than 59°F (15°C). If the air conditioning is activated when the ambient temperature is less than 32°F (0°C), the climate control system will show the current air conditioning setting on the display, but the cooling compressor will not activate.

The right dial controls the air temperature:

- To activate heat, turn the dial to the right (clockwise) up to four available levels. On the temperature display, the highlighted bar will move up accordingly.



When activated, the heat icon will illuminate accordingly on the climate control display.

- To activate air conditioning, turn the dial to the left (counterclockwise) up to four available levels. On the temperature display, the highlighted bar will move down accordingly.



When activated, the air conditioning icon will illuminate accordingly on the climate control display.

- To turn off heating or cooling, turn the temperature dial so the highlighted bar is in the center (OFF) position.



Air Outlets

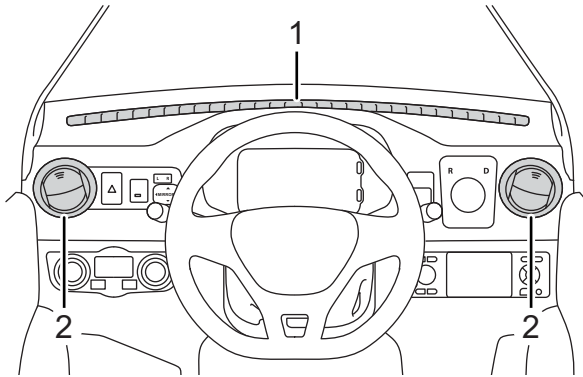

1. Windshield defroster outlet
2. Face vent outlets

Power Windows

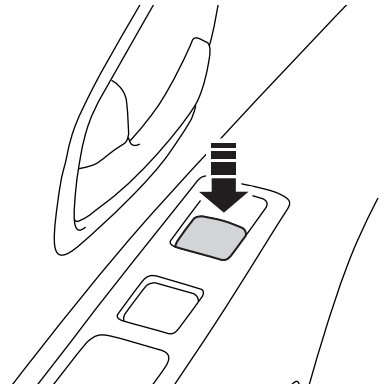

The power window switches are located on both of the side door panels, and each switch controls its own window. To operate a window:

- Ensure that the key switch is in the ON position.
- Push down on the top of the switch to lower the window.
- Pull up on the top of the switch to raise the window.



Seat Heater

WARNING

Do not use the seat heater if you are unable to feel elevated temperatures or pain in any body parts that contact the seat, as you risk burns or other serious injuries. To prevent inadvertent operation of the seat heater, remove the seat heater fuse. See [“Lights and Fuses”, page 7-25.](#)

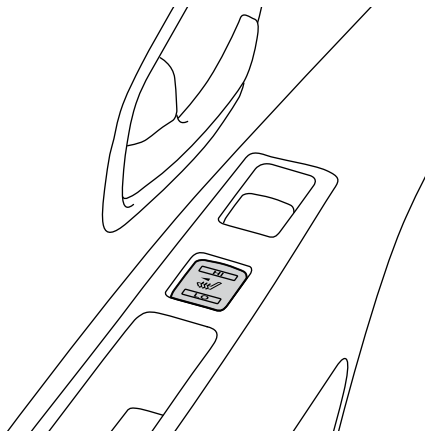

The seat heater is controlled by a 3-position switch on the left door panel. Press HI or LO to set the temperature accordingly, and return the switch to the center position to turn the heater off. The switch will illuminate according to your selection.





Storage Space

WARNING Do not carry bulky items in the interior of the vehicle. They may interfere with your ability to control the vehicle, and can cause injury in the event of a collision.

WARNING Loose objects in the interior of the vehicle can fall into the footwell and interfere with pedal operation, resulting in loss of control.

The SOLO has limited storage and cargo capacity. Plan your trip accordingly to ensure that you have room for any items you may wish to transport.

If they fit securely, small items that you wish to access during a drive can be stored in the bins in either door or in the cup holder. Any items that cannot be stored securely in these places should be stored in the trunk. Do not store loose objects anywhere else in the interior of the vehicle.

Trunk

Operating Precautions

WARNING Do not store heavy or sharp objects in the trunk without securing them. In a collision, these objects may cause the cover to open. Objects thrown from the trunk may injure others or damage the vehicle.

WARNING Never exceed the recommended carrying capacities for the trunk, since this can affect vehicle handling and stability. See [“Vehicle Load Limits”, page 2-3.](#)

CAUTION Do not press the trunk release button on the dashboard or the remote transmitter while the vehicle is moving. Never drive with the trunk open. Driving with an open trunk could cause damage to the vehicle body, and repairs would not be covered by the vehicle warranty.



Trunk

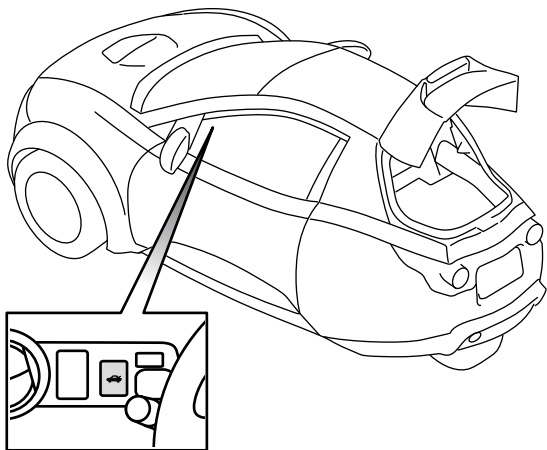

Pressing the trunk release button on the dashboard will open the trunk.

Note: The remote transmitter can also be used to open the trunk. See [“Remote Transmitter”, page 4-26.](#)

Note: The trunk release button on the dashboard is disabled when the vehicle is locked with the remote transmitter.

Emergency trunk release

If the vehicle has no power, the trunk can be opened manually from the inside:

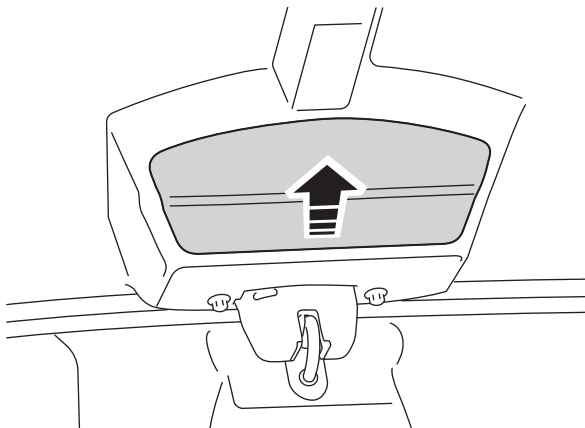

1. Remove the cover at the base of the trunk latch.

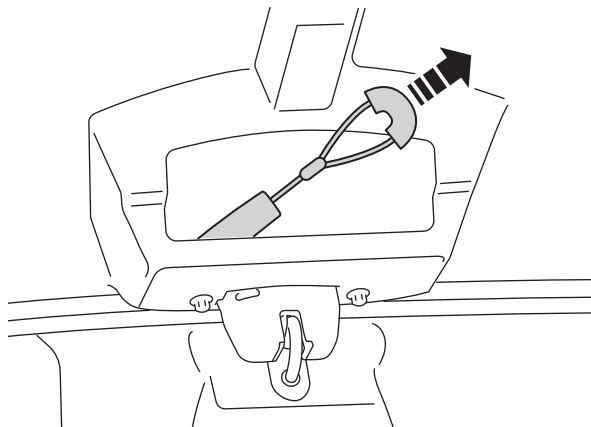

2. Pull the emergency release handle to unlatch the trunk.

Cup Holder

The right door panel has a cup holder that can be folded out when needed.

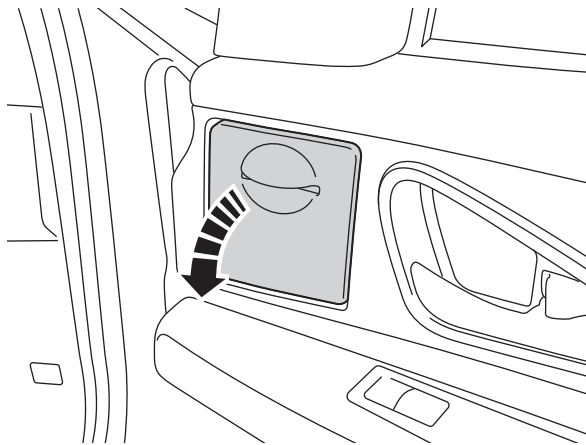

1. Pull the handle down until the tray is level.

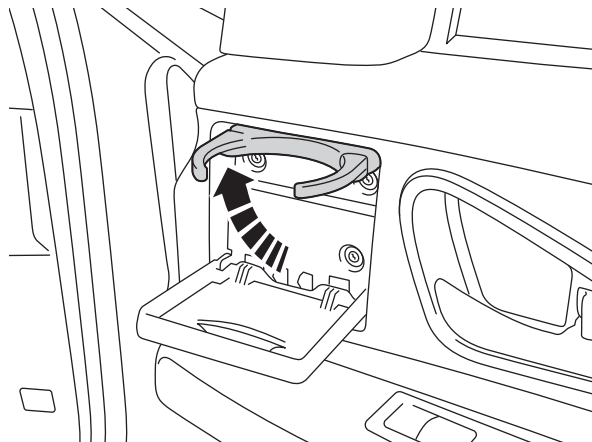

2. Fold the support ring upwards.





High-Voltage Components



WARNING The high-voltage system has no user-serviceable parts. Do not disassemble, remove or replace high-voltage components, cables or connectors. High-voltage cables are colored orange for easy identification.

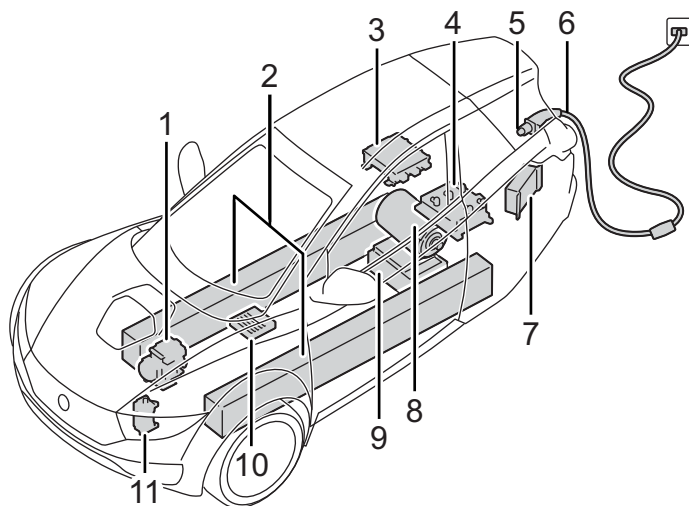

1. A/C compressor
2. High-voltage batteries
3. On-board charger
4. Powertrain controller
5. Charging port
6. Portable charge cable
7. DC/DC converter
8. Drive motor
9. High-voltage distribution box
10. Cabin heater
11. Battery heater



About the High-Voltage Battery

⚠ WARNING The high-voltage battery has no parts that an owner or a non-authorized technician can service. Under no circumstances should you open or tamper with the battery. Always contact an ElectraMeccanica Authorized Repair Facility to arrange for battery servicing.

The high-voltage battery provides power to the motor and the 12V battery, which powers all of the other electrical systems in the vehicle (e.g. lights, instruments, heated seat, etc.).

As you drive your vehicle, the level of charge in the battery is depleted and you will need to recharge it. The built-in charging system allows you to easily recharge it by connecting an electrical power supply to the vehicle's charging port.

Note: The built-in charging system is powered by the 12V battery. For more information, see [“About the 12V Battery”](#), page 7-30.

Note: The actual vehicle range will vary based on driving style. The vehicle consumes more power if you are driving aggressively, driving up hills, or are using more resources (such as heated seats). Over time, the battery experiences a gradual loss of capacity, inherent in all lithium-ion batteries. As your vehicle ages, the capacity of the battery declines.



Environmental Notice: At the end of its service life, the battery should be recycled. Contact ElectraMeccanica for recycling arrangements.

Battery Care

⚠ CAUTION If the battery's charge level falls to 0%, you must plug it in. If you fail to do so within a short period of time, you may permanently damage the battery, and the repairs would not be covered by the vehicle warranty.

If the battery voltage falls to a critically low level (e.g. 1%), it may not be possible to charge the vehicle. Contact an ElectraMeccanica Authorized Repair Facility immediately to prevent permanent damage to the battery.

Preserving battery life

The best way to preserve the battery is to keep it at a low- to mid-level state of charge. Ideally, you should charge the battery so that it reaches full charge right before starting your drive.

Do not leave the charge cable plugged in for long periods if you do not plan to drive for a while.

Storing the vehicle

⚠ CAUTION When storing your vehicle, avoid exposing it to ambient temperatures below -20°C (-4°F) or above 55°C (131°F). Extreme ambient temperatures can greatly reduce the performance and service life of the battery.



Charging the Vehicle

There are two charging methods available for use with your vehicle: Level 1 (portable charge cable) and Level 2 (EV Charge Station). Both methods can be used with your vehicle, since they use the same charging connector.

- Level 1: The portable charge cable is used for slow charging at a 110V outlet. Your vehicle is supplied with this cable, which connects to most standard (110V) power outlets.
- Level 2: An EV Charge Station (also known as a wall-mounted charging unit or public charging station) charges much faster than Level 1 charging.

Note: ElectraMeccanica does not recommend monopolizing a public EV Charge Station when your vehicle is sufficiently charged for your trip. In the developing culture of electric vehicles, it has become a matter of courtesy to only use public stations if your vehicle is in need of charging, especially when limited stations are available. Be aware that some privately-owned lots (such as shopping malls) may enact rules that allow the towing of vehicles unnecessarily monopolizing their stations.

Using the Charge Cable

Your vehicle is supplied with a portable charge cable that connects to most standard (110V) power outlets, allowing you to charge your vehicle while at home or away.

The portable charge cable is located in its storage space under the hood.

Electrical outlets

⚠ WARNING Do not use extension cords, multi-outlet power strips, splitters, grounding adapters, surge protectors, or similar devices, as these may increase the risk of electric shock, fire, or other hazards.

⚠ WARNING Charging an electric vehicle can stress a building's electrical system more than a typical household appliance. Follow the special precautions in this section to reduce the risk of electric shock and fire while charging.

For home charging, ElectraMeccanica recommends having a qualified electrician inspect and verify that the electrical system (including the electrical outlet, wiring, junctions, and protection devices) is rated for heavy-duty service at a 15 amp continuous load. Whether charging at home or away, check the following:

- Check the charge cable for signs of damage. Do not use a damaged cable.



- Use a properly-grounded, three-prong outlet.
- Ensure that the outlet can provide 15A of continuous current. A dedicated circuit with a 15A or higher breaker or fuse is preferable. If a dedicated circuit is not used, check that the current draw of the vehicle (15A) plus any other devices connected to the circuit does not exceed the circuit's rating. There should be no other major appliances connected to the same circuit.
- If charging outdoors, use a weatherproof electrical outlet.
- Never use an extension cord, power strip, splitter, grounding adapter, surge protector or any similar device. Connect the charge cable directly to the outlet.
- Position the charge cable to avoid strain on the outlet, cable, and plug. Route the cable so it is dry and protected from damage (e.g. being driven on, tripped over, etc.).

If you must use an electrical outlet with unknown conditions:

- Always visually inspect the condition of the outlet before connecting the charge cable.
- Do not use an electrical outlet that appears worn or damaged, or will not hold the plug firmly in place.
- After 10 minutes of charging, check both the electrical outlet and the plug while charging, and discontinue use if the outlet or plug is hot.

Connecting the Charge Cable

⚠ WARNING Always position the charge cable so that it will not be driven over, stepped on, tripped over, or otherwise damaged or stressed while in use. To prevent a tripping hazard, as well as damage to or loss of the charge cable, always store it in its storage space under the hood of the vehicle after every use.

⚠ CAUTION The connector end of the charge cable is heavy and can damage the vehicle's paint if mishandled while connecting or disconnecting.

Position the vehicle so that the charge cable easily reaches the charging port on the rear of the vehicle and the electrical outlet on the wall.

1. Remove the portable charge cable from its storage space under the hood. See [“Hood”, page 4-28](#).
2. Place the vehicle in N (Neutral) with the key switch in the OFF position and set the parking brake. See [“Electronic Parking Brake \(EPB\)”, page 4-18](#).
3. Plug the charge cable into an electrical wall outlet. Always connect the charge cable to a **grounded** 15 amp outlet. Never use an extension cord.
4. Verify the **Power** status on the charge cable box.

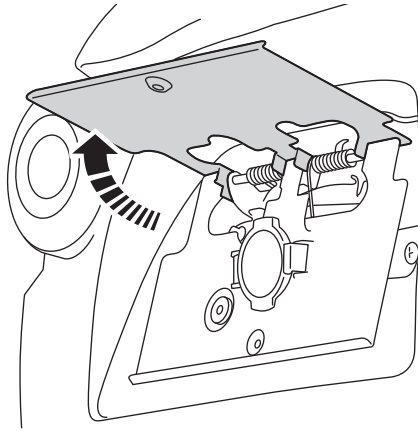

5. The vehicle's SAE J1772 charging port is located behind the license plate and can be accessed by lifting up on the spring-loaded rear license plate holder.

Note: In cold weather conditions, ice may form around the license plate. Remove ice from the area before attempting to open or close the license plate.

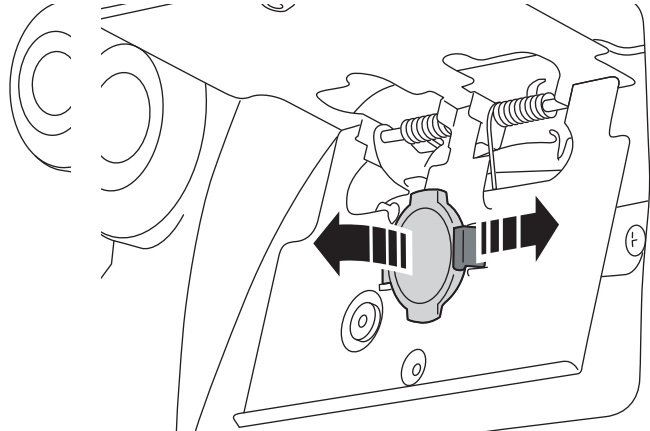

6. Pull the latch outward (to the right) to release the charging port cover, then pull the cover outward (to the left) to open it.
7. Connect the charge cable to the vehicle's charging port. A spring-loaded clip on the front of the connector engages with the port to lock it in place.

Note: If the Electronic Parking Brake (EPB) has not been engaged when the charge cable is plugged in, it will engage automatically. See [“Electronic Parking Brake \(EPB\)”](#), page 4-18.



Charging Instructions

Note: When the charge cable is plugged into the vehicle, Drive Mode is inhibited to prevent the vehicle from being driven.

- Verify the charger status on the charge cable box.

Note: During charging or in high ambient temperatures, the vehicle's internal cooling fan may automatically switch on for a period of time to cool the cells in the high-voltage battery. The fan may be audible while in operation; this is normal and not a cause for concern. Additional unexpected clicking sounds may be heard while the vehicle is charging; these sounds are also normal.

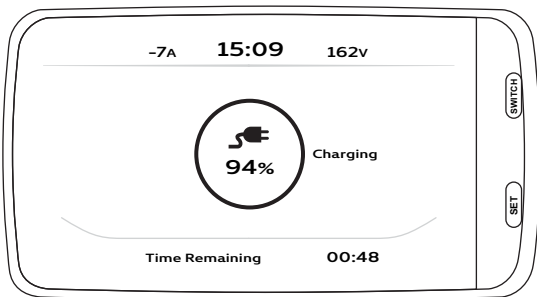
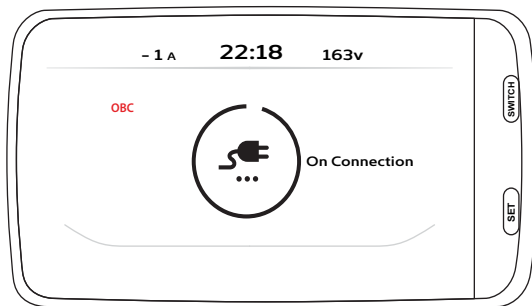

- The charging status and estimated time to full charge will be displayed on the instrument cluster display.

OBC If the battery is not charging, the OBC icon will illuminate on the instrument cluster display. If this occurs, unplug the charge cable from the vehicle and plug it back in. If the icon remains illuminated, contact an ElectraMeccanica Authorized Repair Facility. Do not drive the vehicle, as you risk draining the battery to 0%.



Estimating Charging Time

The amount of time it takes to fully charge the vehicle is dependent upon the remaining battery charge level and the available electrical supply (amperage and voltage).

Note: *Charging time is also impacted by both the ambient air temperature and the temperature of the vehicle's battery. When charging in low- or high-temperature weather, the thermal management system will use power to regulate the battery temperature, which will increase charging time.*

Use the following table as a guideline when estimating how long it will take to charge your vehicle. This table assumes you are charging a fully-depleted battery to a full charge.

Electrical supply voltage	Estimated charging time (hours)
120V AC	12 hours 0-80%; 15 hours 0-100%
220V AC	2.5 hours 0-80%; 4 hours 0-100%

Disconnecting the Charge Cable



CAUTION

To keep debris out of the charging port, ensure the charging port cover is closed when the charge cable is not connected.

1. Press the button on the charge cable connector to release the locking clip.
2. Pull the connector from the charging port.
3. Close the charging port cover and press firmly to ensure that it latches securely into place.
4. Lower the license plate holder.
5. Unplug the charge cable from the electrical outlet.
6. Store the charge cable in its storage space under the hood. See [“Hood”, page 4-28](#).



Distracted Driving

⚠️ WARNING Taking your eyes off the road for too long or too often could cause a collision resulting in injury or death. Focus your attention on driving.

⚠️ WARNING Use extreme caution when using any device that may take your focus off of the road. Your primary responsibility as the driver is the safe operation of your vehicle. Only use cell phones and other devices not essential to driving when parked. Driving while distracted can result in loss of vehicle control, collision, and serious bodily injury or death.

To avoid distracted driving, keep your eyes on the road, keep your hands on the steering wheel, and focus your attention on driving.

- Do not use a phone or other hand-held devices while driving.
- Watch the road. Do not read, text, type, or look up information on phones or other electronic devices.
- Become familiar with vehicle features before driving, such as programming favorite radio stations and adjusting climate control and seat settings. Program all trip information into any navigation device prior to driving.
- Wait until the vehicle is parked to retrieve items that have fallen to the floor.

Defensive Driving

Drive defensively and always expect the unexpected. The first step in driving defensively is to wear your seat belt. See [“Seat Belt”, page 3-4](#) for more information.

- Always focus on the task of driving.
- Assume that other drivers will be careless and make mistakes; anticipate what they might do and be ready to react.
- Allow enough distance between you and the vehicle in front of you to help prevent a collision in case of sudden stops or other hazards.
- Be aware of your surroundings while operating the vehicle. Because the SOLO is a small vehicle, other drivers may be less likely to be aware of your presence. Before executing turns or lane changes, use your mirrors and turn your head to check any blind spots to help avoid collisions.



Impaired Driving

⚠️ WARNING Carefully read all labels and warnings on any prescription or over-the-counter medication you take before driving. Ensure that it does not cause dizziness, drowsiness, or other side effects which may impair your driving and lead to a collision.

⚠️ WARNING NEVER drive while under the influence of illegal drugs. Drugs can affect your judgment, reflexes, and perception in unexpected ways, which could lead to a serious (or even fatal) collision.

⚠️ WARNING NEVER drive while under the influence of alcohol or marijuana. Driving under the influence of alcohol or marijuana is very dangerous; your reflexes, perceptions, attentiveness, and judgment can be affected by even a small amount of these substances. You could have a serious or fatal collision if you drive while impaired.





Starting the Vehicle

WARNING Before entering the SOLO, visually check around and underneath the vehicle for children, animals, or objects that may be struck by the moving vehicle.

CAUTION Spinning the tires or holding the vehicle in one place on a hill using only the accelerator pedal may damage the drive system. When stopping on a hill, use the brakes to hold the vehicle in place.

Before starting the vehicle, verify that:

- The charge cable is disconnected and stored under the hood. See [“Disconnecting the Charge Cable”, page 5-7.](#)
- The vehicle is properly parked with the Electronic Parking Brake (EPB) engaged and the Drive Mode set to N (Neutral). See [“Parking”, page 6-7.](#)

Note: This vehicle will creep forward or backward when the brakes are not applied and the Drive Mode Selector is in D (Drive) or R (Reverse).

With both vehicle doors closed and your seat belt fastened:

1. Insert the key into the key switch. See [“Key Switch”, page 4-6.](#)
2. Press down on the brake pedal until it is fully depressed and hold it down.

3. Without moving the steering wheel, turn the key to the ON position. The display will show the ElectraMeccanica logo, then load the instrument cluster display. All indicators will flash briefly. See [“Instrument Cluster Display”, page 4-9.](#)

Note: Do not move the steering wheel while cycling the key switch from OFF to ON, as this can result in a fault. If the fault occurs, see [“EPS and Fault indicators on key-on”, page 4-16.](#)

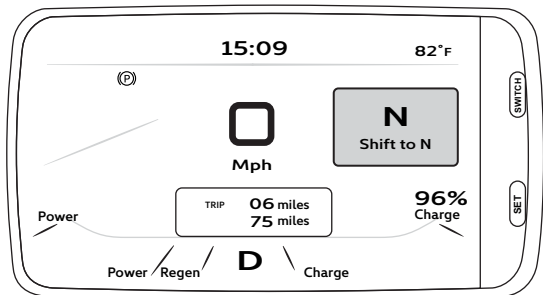

4. Ensure that the Drive Mode Selector is set to N (Neutral). See [“Drive Mode Selector”, page 4-7.](#)

Note: As illustrated, if the Drive Mode Selector is not currently set to N (Neutral), you will be prompted to do so by the display.

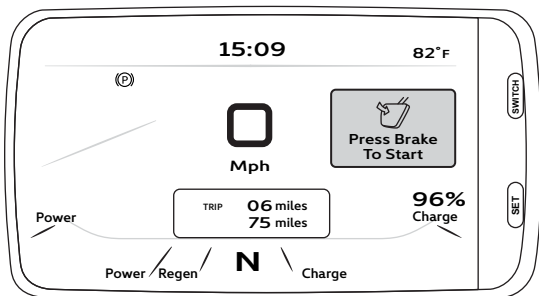

5. Turn the key clockwise past the ON position to the START position.

Note: As illustrated, if the brake pedal is not currently pressed, you will be prompted to do so by the display.

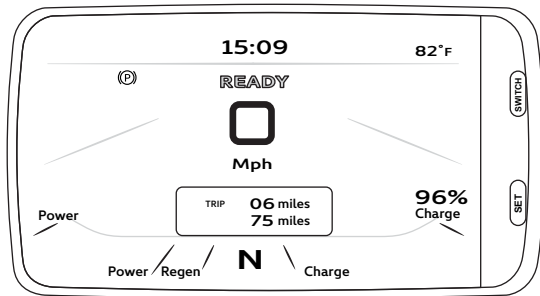

6. Allow the key to return to the ON position. The READY indicator will illuminate on the instrument cluster display. Your vehicle is now ready to be driven.
7. With your foot still holding the brake pedal, turn the Drive Mode Selector from N (Neutral) to the position you want to use: D (Drive) or R (Reverse). The current position of the switch is indicated on the instrument cluster display. See [“Drive Mode Selector”, page 4-7](#).
8. Release the Electronic Parking Brake (EPB) by pushing the EPB switch. See [“Electronic Parking Brake \(EPB\)”, page 4-18](#).
9. Release the brake pedal and press the accelerator pedal down, which will increase the speed in the direction selected by the Drive Mode Selector.



Braking

Pressing the brake pedal down will increase the amount of braking force. When braking, your foot should be off the accelerator pedal. Progressive use of the brakes should bring the vehicle to a complete stop without locking the wheels. If heavier braking is necessary, it is recommended to pump the brake pedal in order to avoid locking the wheels.

Note: *This vehicle does NOT have an anti-lock brake system (ABS).*

Rules for safe braking

- Always leave enough space between your vehicle and others.
- Actual stopping distances vary greatly with many factors, such as the road surface (whether it is pavement or gravel), the condition of the road (whether it is wet, dry, or icy), tire tread, the condition of the brakes, the weight of the vehicle, and the amount of brake force applied.
- Avoid needless heavy braking. Some people drive in spurts (heavy acceleration followed by heavy braking) rather than keeping pace with traffic, which is a mistake. Keeping pace with traffic and allowing reasonable following distances reduces unnecessary braking, which means longer brake life.

Stopping on hills and slopes

When stopping on a hill or slope while the vehicle is in **D** (Drive) or **R** (Reverse) (e.g. at a stoplight), you can engage the Electronic Parking Brake (EPB):

1. Use the brake pedal to bring the vehicle to a stop.
2. Hold your foot on the brake pedal and engage the EPB. See [“Electronic Parking Brake \(EPB\)”, page 4-18.](#)
3. Once the EPB has engaged, you can release the brake pedal.
4. When you need to start moving again, press the accelerator pedal. The EPB will automatically disengage.



Hill Start Assist system

⚠ WARNING Do not rely exclusively on the Hill Start Assist system to keep your vehicle stationary on a hill. Always use the pedal-operated brakes to prevent the vehicle from rolling backward. Failure to do so could result in a collision or property damage.

⚠ WARNING The Hill Start Assist system may not prevent the vehicle from rolling under certain conditions (e.g. slippery roads, unpaved roads, steeply-graded slopes, or carrying heavy loads). Always be prepared to use the brakes to hold the vehicle on a hill.

The Hill Start Assist system is designed to reduce the vehicle rolling downhill when accelerating from a stop.

The Hill Start Assist system is designed to reduce rollback in the time it takes the driver to release the brake pedal and apply the accelerator when the vehicle is stopped on a hill. The amount of rollback is dependent on vehicle load and grade of slope the vehicle is on. Hill Start Assist is not intended to prevent rollback for more than 2 seconds.

Hill Start Assist will operate automatically when the brake pedal is released under the following conditions:

- The Drive Mode Selector is set to **D** (Drive) with the vehicle pointing uphill. See [“Drive Mode Selector”, page 4-7](#).
- The Drive Mode Selector is set to **R** (Reverse) with the vehicle pointing downhill.

Regenerative Braking

⚠ WARNING Regenerative braking does not replace the need to use the brake pedal to stop the vehicle.

Note: Because regenerative braking does not activate the brake light, vehicles behind you will not be alerted that you are slowing.

Whenever your vehicle is moving and your foot is off the accelerator, regenerative braking slows the vehicle and feeds energy back to the vehicle's battery. At very high state of charge, regenerative braking will be limited or turned off.

By anticipating your stops and removing your foot from the accelerator to slow down, you can take advantage of the energy gained from regenerative braking to increase your vehicle's range.

The current amount of energy gain can be viewed on the Power/Regen gauge on the instrument cluster display. See [“Power/Regen gauge”, page 4-13](#).



Parking

With the vehicle at a complete stop and your foot on the brake pedal:

1. Turn the Drive Mode Selector Switch to N (Neutral). See [“Drive Mode Selector”, page 4-7](#).
2. Apply the Electronic Parking Brake (EPB). See [“Electronic Parking Brake \(EPB\)”, page 4-18](#).
3. Turn the key to the OFF position and remove the key from the key switch. The key should be removed from the vehicle when parked to prevent theft. See [“Key Switch”, page 4-6](#).
4. Charge the battery if needed. See [“Charging Instructions”, page 5-3](#).

Parking on hills and slopes

⚠️ WARNING When parking on a hill or slope, set or “curb” your wheels accordingly before applying the EPB. This additional safety measure prevents your vehicle from rolling into traffic in the event of a brake failure, or if your vehicle is struck by another vehicle.

Note: Traffic laws in your location may require curbing your wheels when parking on even a slight slope. Ideally, you should make a habit of curbing the wheels whenever you park on the side of a road.

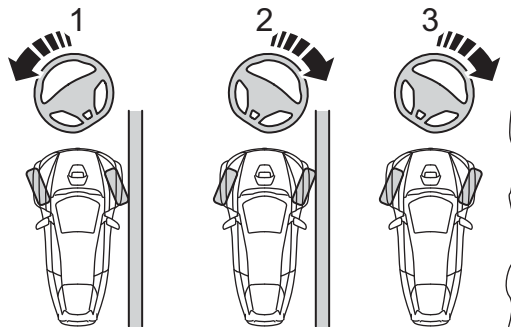

1. **Uphill:** Turn the front wheels away from the curb, then slowly let your vehicle roll backward until the wheel gently touches the curb. Set the EPB.
2. **Downhill:** Turn the front wheels toward the curb, then slowly let your vehicle roll forward until the wheel gently touches the curb. Set the EPB.
3. **Uphill/Downhill with no curb:** Turn the front wheels toward the side of the road, then set the EPB.



A series of 15 horizontal dashed lines for writing.



General Information

The safety, reliability, and performance of your vehicle will depend partly on how well it is maintained. Maintenance is the owner's responsibility. You must ensure that the appropriate maintenance is performed when required and according to the recommendations specified by ElectraMeccanica.

Regular maintenance can help protect against major repair expenses resulting from neglect or inadequate maintenance. It may also help to maintain the value of the vehicle if it is sold.

Owner Maintenance

⚠️ WARNING Any significant or sudden drop in fluid levels or uneven tire wear should be rectified immediately.

In addition to the scheduled maintenance, you should carry out a pre-drive inspection before each trip to keep your SOLO in safe operating condition. See [“Pre-Drive Inspections”, page 2-5](#).

While driving your vehicle, be alert if any of the following conditions manifest and have them inspected by an ElectraMeccanica Authorized Service Provider as soon as possible:

- Take notice of any vibrations in the steering wheel, noticeably increased or decreased steering effort, or a change in the steering wheel's straight-ahead position.
- When traveling in a straight path on smooth, level roads, notice if your vehicle continuously turns slightly or pulls to one side.
- When braking, notice any unusual sounds, pulling to one side, or noticeably increased or decreased effort while operating the brake pedal.



Initial Required Maintenance

To maintain the warranty, the vehicle must be brought to an approved ElectraMeccanica Authorized Service Provider for initial servicing in the first 500–1,000 mi (750–1500 km) or in the first 6 months of ownership, whichever comes first.

The labor required for checking, adjusting, and tightening components planned by ElectraMeccanica will be performed free of charge (except for consumables and small supplies). After completing these operations, an authorized ElectraMeccanica representative will record that the initial required maintenance has been carried out, the date of service, and the exact mileage. See [“Service History”, page 9-1](#).

Subsequent servicing as defined in this manual maintains the warranty for the period specified upon vehicle delivery.

Scheduled Maintenance

The scheduled maintenance requirements for your vehicle are shown later in this section. See [“Maintenance Schedule Chart”, page 7-4](#).

Some of the necessary maintenance and servicing of your vehicle will require special knowledge or equipment, and should preferably be entrusted to the trained technicians at your ElectraMeccanica Authorized Service Provider.

Parts and Maintenance Items

The proper replacement parts, fluids, and lubricants to use are listed in the table below.

Part/Usage	Number/Requirement
Brake Fluid	DOT 4
Coolant	Coolant should only be topped off or changed by an ElectraMeccanica Authorized Service Provider. Only use a 50/50 mix of ethylene glycol coolant and distilled water.
Windshield Washer	Automotive windshield washer fluid that meets regional freeze protection requirements
Windshield Wiper	21" (300 mm) blade
Remote Keyless Entry Transmitter Battery	CR1632 (1 per remote)
Weatherstripping Conditioner	303® Aerospace Protectant
Keylock Cylinders	Würth Lock Cylinder Spray
Hood, Door, and Liftgate Hinges	Würth Premium White Lithium Grease Spray



General Maintenance Safety Information

WARNING For your personal safety, do not attempt inspections or repairs not fully described in this manual. Contact your ElectraMeccanica Authorized Service Provider for service if you cannot determine the cause of a problem, or if the inspection or repair exceeds your abilities or resources.

WARNING Never perform an inspection or repair with the key switch in the ON position, unless otherwise specified. See [“Key Switch”, page 4-6](#).

WARNING Never perform an inspection or repair with the Drive Mode Selector in D (Drive) or R (Reverse). See [“Drive Mode Selector”, page 4-7](#).

High-Voltage Safety Information

WARNING Exposure to high voltage can cause shock, burns, and even death.

WARNING Never try to do your own service on high-voltage components. You risk serious injury or death and damage to your vehicle if you attempt to do your own service work. Service and repair of these high-voltage components should only be performed by a trained service technician with the proper knowledge and tools.

WARNING Damage to the high-voltage battery or high-voltage system can create a risk of electric shock, overheating, or fire.



High-voltage components are identified by labels. These labels may include the symbol for risk of electric shock (illustrated here). Do not remove, open, take apart, or modify these components. See [“High-Voltage Components”, page 5-1](#).

High-voltage cable or wiring has orange covering or labels. Do not probe, tamper with, cut, or modify high-voltage cables or wiring.

If the high-voltage electrical system senses a problem, it may shut down the system. When this occurs, the high-voltage battery is disconnected and the vehicle will not operate. Before the vehicle can operate again, it must be serviced at an ElectraMeccanica Authorized Service Provider.

If the vehicle is damaged from a moderate to severe collision, flood, fire, or other event, the vehicle should be inspected as soon as possible. Only an ElectraMeccanica Authorized Service Provider or a trained service technician with the proper knowledge and tools should inspect, test, or replace the high-voltage battery.

Note: Any attempt by an unauthorized party to repair, replace, alter, modify, or tamper with the high-voltage battery will void the warranty.



Maintenance Schedule Chart

The scheduled maintenance or service must be performed in accordance with the chart below to keep your vehicle in top operating condition.

The service intervals in this maintenance and service schedule are based on average driving conditions. Some items will need more frequent service if you drive in unique conditions, such as unusually wet or dusty areas. Consult your ElectraMeccanica Authorized Service Provider for recommendations applicable to your individual needs and use.

Maintenance / Service	Every Month	500 mi (750 km) or 6 months	10,000 mi (15,000 km) or 12 months	20,000 mi (30,000 km) or 24 months	30,000 mi (45,000 km) or 36 months	40,000 mi (60,000 km) or 48 months	50,000 mi (75,000 km) or 60 months
Inspect Seat Belt Retractor	●						
Check Tire Pressure	●						
Check Brake Fluid	●						
Inspect Tires	●						
Full Inspection Service		●	●	●	●	●	●
Inspect & Adjust Drive Belt		●	●	●	●	●	●
Replace Drive Belt and Pulley				●		●	
Replace Cabin Filter			●	●	●	●	●
Replace Keyless Entry Battery				●		●	
Replace Brake Fluid							●
Replace Front & Rear Coolant							●



Full Inspection Service

Your SOLO should be given a full inspection service every 10,000 miles (15,000 km) or every 12 months, whichever comes first. This service includes the following procedures:

1. Check all vehicle software for updates to be installed
2. Vehicle road test:
 - Check all exterior lights
 - Check operation of brake and accelerator pedals
 - Check for abnormal operation noise
 - Check vehicle handling, steering feel, and steering wheel alignment
3. Inspect all body panels, before and after inspection service
4. With rear skirt and close-out panels removed:
 - Inspect drive belt tension and condition
 - Inspect condition of drive sprocket and pulleys
 - Clean rear shock mounts and lubricate as needed
 - Inspect brake line, brake pad, and rotor condition
 - Ensure that all rear electrical connections are secured, clean and connected
 - Check coolant level
 - Inspect for radiator damage or coolant system leaks
 - Inspect charging port condition, operation, and seal
 - Ensure electrical connections for brake and accelerator
5. Inspect rear wheel for proper seating, lug nuts, tire wear, and tire pressure
5. Reinstall close-out panels and confirm no significant tire rubbing; reinstall skirt
6. Trunk inspection:
 - Check operation using keyless entry and dashboard switch
 - Check weatherstripping condition and lubricate if needed
 - Check latch and striker alignment and operation
7. Inspection of exterior doors:
 - Check alignment, including latch and striker alignment and operation
 - Lubricate door check straps, door handle pivot points, and window seals
 - Inspect weatherstripping condition and lubricate if needed
8. Interior inspection:
 - Inspect seat belt retractor and latch operation
 - Inspect seat adjustment operation and lubricate rails if needed
 - Ensure that all controls and switch operations function as designed
 - Check radio head unit operation and reception pedals are clean and secure



9. With liner removed and hood supported:
- Inspect front wheels for proper seating, lug nuts, tire wear, and tire pressure
 - Inspect condition of brake lines, brake pads, and rotors
 - Inspect ball joints
 - Inspect steering rack boots for damage
 - Check anti-roll bar bushings and lubricate if needed
 - Check brake master cylinder fluid levels
 - Check windshield washer fluid level
 - Check wiper blade for damage and wiper arm for alignment
 - Inspect 12V battery positive (+) terminal and cover condition; confirm correct voltage at terminal.





Maintenance Cover

To access some parts of the vehicle, the maintenance cover will need to be removed.

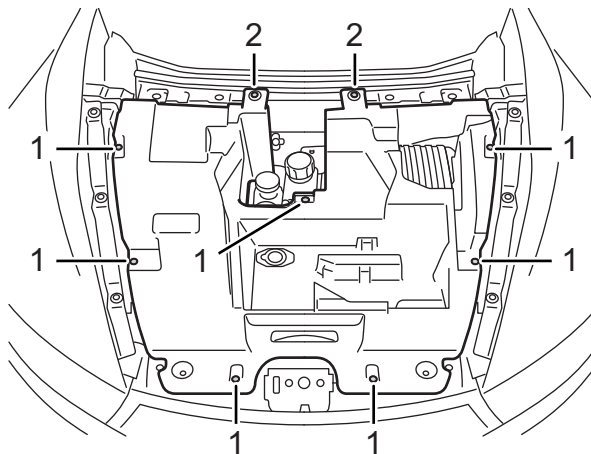

To remove the cover: with the vehicle keyed OFF, carefully remove the seven screws (1) and two bolts (2) holding the cover in place, then lift it off.

To replace the cover, fit it back into place and align the holes with the attachment points. Install the screws and bolts to hold it in place.

Component Locations

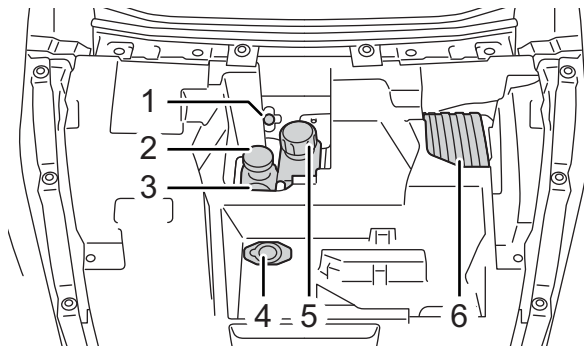

1. 12V battery positive (+) terminal ([page 7-30](#))
2. Front brakes fluid reservoir ([page 7-8](#))
3. Rear brake fluid reservoir ([page 7-8](#))
4. Washer fluid reservoir ([page 7-10](#))
5. Battery coolant reservoir ([page 7-12](#))
6. Under-hood fuse center ([page 7-25](#))



Brake Fluid

WARNING Brake fluid is highly toxic. Keep containers sealed and out of the reach of children. If accidental consumption of brake fluid is suspected, seek medical attention immediately.

WARNING Prevent brake fluid from coming into contact with the skin or eyes. If this occurs, rinse immediately with plenty of water.

WARNING If brake pedal travel is increased or if there is any significant loss of brake fluid, it is recommended that you have the vehicle recovered to an ElectraMeccanica Authorized Service Provider immediately. Driving under such conditions could result in extended stopping distances or complete brake failure. See [“Vehicle Recovery”](#), page 7-42.

Check the brake fluid level monthly. The level should be checked more frequently in high mileage conditions.

The level of fluid in the brake reservoirs may fall slightly during use as a result of brake pad wear, and will need to be topped up from time to time.

Brake fluid specification

Any proprietary brand of brake (or brake and clutch) fluid meeting DOT 4 specification can be used in your SOLO.

Checking the fluid level

WARNING DO NOT drive if the fluid level is below the MIN mark on the reservoir.

The two brake fluid reservoirs are located under the hood.

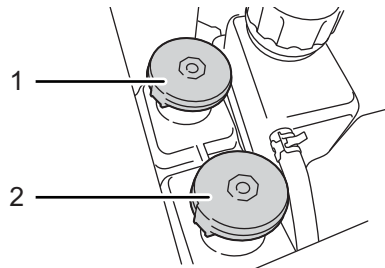

1. Front brake system reservoir
2. Rear brake system reservoir

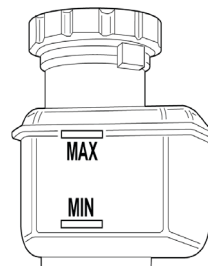

For accuracy, check the fluid level with the vehicle standing on level ground and the maintenance cover removed. See [“Maintenance Cover”](#), page 7-7.

The level of fluid can be seen through the body of the reservoir, and should be between the MIN and MAX marks.



Topping up the brake fluid



WARNING Only use new fluid from an airtight container. Fluid from open containers or fluid previously bled from the system will have absorbed moisture, which will adversely affect performance, and must not be used.



CAUTION Brake fluid will damage painted surfaces and can cause body panels to crack. Soak up any spillage with an absorbent cloth immediately and wash the area with a mixture of car shampoo and water.

1. Open the hood. See [“Hood”, page 4-28](#).
2. Clean the reservoir cap with a clean, dry cloth before removing to prevent dirt or moisture from entering the reservoir.
3. Position an absorbent cloth around the reservoir to absorb any brake fluid spillage.
4. Remove the reservoir cap by turning it counterclockwise (left).
5. Fill the reservoir with an approved brake fluid until the fluid level is at the **MAX** fill mark.
6. Replace the reservoir cap and remove the cloth.





Washer Fluid

⚠ WARNING Some windshield washing products are flammable, particularly in undiluted concentrations. Do not allow washer fluid to come into contact with open flames or sources of ignition.

⚠ WARNING If the vehicle is operated in temperatures below 40°F (4°C), use a washer fluid with frost protection. In cold weather, failure to use a washer fluid with frost protection could result in impaired vision and an unsafe driving condition.

Check and fill up the reservoir level monthly (or more frequently in high-use conditions).

Operate the washer periodically to check that the nozzle is clear and properly directed.

Washer fluid specification

Any automotive windshield washer fluid that meets regional freeze protection requirements can be used in your SOLO.

Filling up the washer reservoir

The windshield washer fluid reservoir is located under the hood.

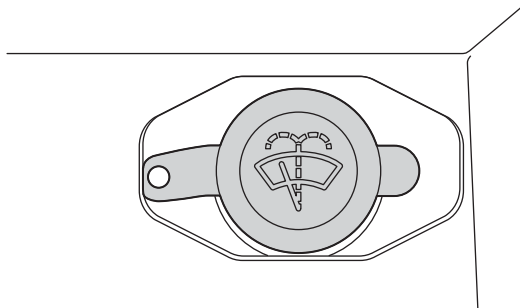

1. Open the hood (See [“Hood”, page 4-28](#)).
2. Remove the charge cable from its storage space.
3. Clean the reservoir cap with a clean, dry cloth before opening to prevent dirt or contaminants from entering the reservoir.
4. Position an absorbent cloth around the reservoir to absorb any washer fluid spillage.
5. Fill the reservoir with an approved washer fluid until the fluid is visible just below the reservoir neck.
6. Close the reservoir cap and remove the cloth.
7. Return the charge cable to its storage space.



Checking the Wiper Blade

CAUTION Only use cleaning products that have been approved for use on automotive glass and rubber. Inappropriate products may cause damage.

Periodically check and clean the wiping edge of the wiper blade. Clean the blade edge by wiping with a soft cloth or sponge, using warm, soapy water.

Check the blade rubber for cracks, splits and roughness. If any damage is found, replace the blade immediately to prevent damage to the windshield glass.

Replacing the Wiper Blade

Replace the wiper blade at least once per year for optimum performance. For blade size, see [“Parts and Maintenance Items”, page 7-2](#).

Poor wiper quality can be improved by periodically cleaning the wiper blade and the windshield.

Removing the wiper blade

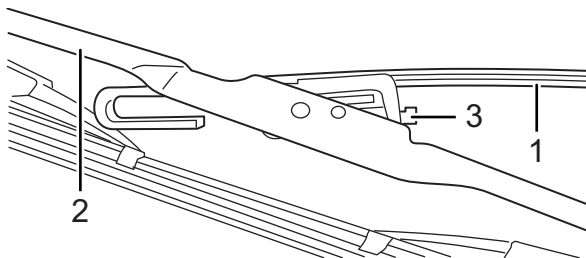

1. Lift the wiper arm (1) away from the windshield.
2. Turn the wiper blade (2) perpendicular to the arm to expose the locking tab (3).
3. Push in and hold the locking tab.
4. Slide the blade down towards the wiper arm until it releases from the hook at the end of the arm, then release the locking tab.
5. Slide the blade upwards off the wiper arm to remove it.

Installing the wiper blade

1. Slide the wiper arm through the opening in the wiper blade, and position the arm hook around the fitting in the center of the blade.
2. Pull the wiper blade down towards the hook until it snaps securely into place.



Battery and Drive Motor Coolant



This vehicle uses a specific type of coolant which should never be mixed with other coolant types. See [“Parts and Maintenance Items”, page 7-2.](#) Do not allow anyone except an ElectraMeccanica Authorized Service Provider to top off or change the coolant, as this could damage the system and void the warranty.

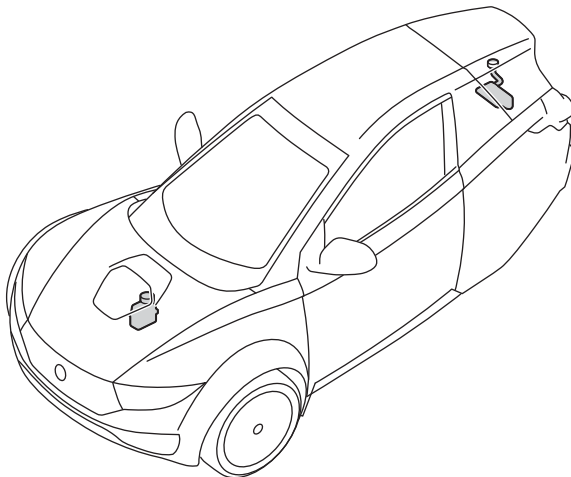

The vehicle contains two coolant reservoirs. The reservoir under the hood beneath the maintenance cover is for the high-voltage battery system, and the one located in the rear is for the drive motor system.

The coolant levels should be checked and replaced as needed by an ElectraMeccanica Authorized Service Provider during the scheduled maintenance intervals. See [“Maintenance Schedule Chart”, page 7-4.](#)



Checking Drive Belt Tension

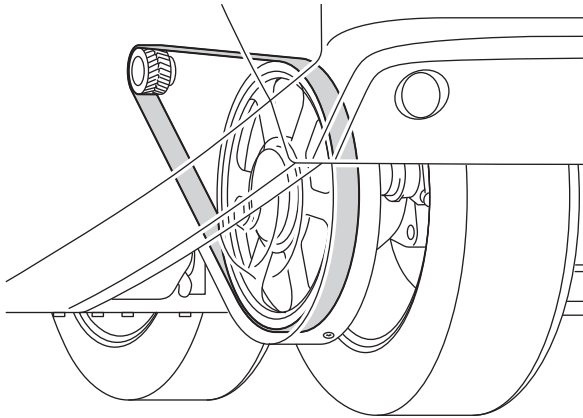

Proper belt tension is essential for optimal operation of the drive system. Lack of belt tension can lead to “ratcheting,” which causes the teeth of the belt to slide over the teeth of the rear sprocket. This causes an unpleasant sound. If you suspect ratcheting has occurred, contact your ElectraMeccanica Authorized Service Provider to have the belt inspected.

The drive belt is located by the rear wheel of the vehicle, behind a cover. It is not immediately visible or accessible.

The drive belt provides low maintenance and quiet operation with minimal stretch. The drive belt tension should be checked and adjusted at the intervals specified in the Maintenance Schedule. See [“Maintenance Schedule Chart”](#), page 7-4.



Inspection and Maintenance

⚠ WARNING Defective tires are dangerous. Do not drive if any tire is damaged, excessively worn, or inflated to an incorrect pressure.

⚠ WARNING Avoid contaminating tires with vehicle fluids that can degrade rubber and potentially result in a blowout.

Regularly inspect the wheels and tires for the following:

- Bent or cracked wheel rims
- Impact marks on the wheel rims
- Cuts, cracks, or splits in the tire tread or sidewall area
- Bumps or bulges within the tire body

If any of the wheels or tires are found to be damaged, replace them immediately.

Good driving practices will improve the mileage you obtain from your tires and avoid unnecessary damage:

- Always ensure that the tire pressures are correctly adjusted.
- Always observe the posted speed limits and advisory speeds.
- Avoid pulling away quickly or hard acceleration.
- Avoid making fast turns or braking sharply.
- Avoid potholes and objects in the road.

- Do not run over curbs or hit the tire against the curb when parking.

Wheel alignment and tire balance

Unbalanced wheels (sometimes noticeable as vibration through the steering) may affect vehicle handling and tire life. Even with regular use, wheels can get out of balance. Therefore, you should have your wheel balance checked as required.

Note: *If tire wear is uneven (on one side of the tire only) or becomes abnormally excessive, you should get the alignment checked by an ElectraMeccanica Authorized Service Provider.*



Tire wear

WARNING The tires should be regularly checked for wear and to make sure that there are no cuts, bulges or exposure of the ply/cord structure. Do not drive with tires that are worn or damaged. The safety of the vehicle and driver will be adversely affected.

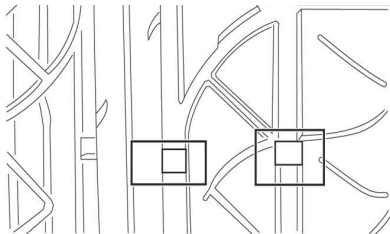

Tires fitted as original equipment have wear indicators molded into the tread pattern.

When the tread has been worn down to 1/16" (1.6 mm), the indicators start appearing at the surface of the tread pattern, producing the effect of a continuous band of rubber across the width of the tire.

A tire must be replaced as soon as an indicator band becomes visible or the tread depth reaches the minimum permitted by legislation.

Age degradation

Tires degrade over time due to the effects of ultraviolet light, extreme temperatures, high loads, and environmental conditions. It is recommended that tires are replaced every six years, or sooner if required.



Punctured tires

⚠ WARNING Do not drive the vehicle with a punctured tire. Even if the punctured tire has not deflated, it is unsafe to use, since the tire may deflate suddenly at any time.

Your vehicle is fitted with tubeless tires, which may not leak when penetrated, provided the object remains in the tire.

If, however, you feel a sudden vibration or ride disturbance while driving, or you suspect your tire or vehicle has been damaged, immediately reduce your speed. Drive slowly, avoiding heavy braking or sharp steering, and stop the vehicle when it is safe to do so.

Inspect the tires for damage. If a tire is underinflated and does not appear to have any damage to the sidewall, you can try to temporarily repair it using the supplied tire repair canister. If you cannot detect the cause or the tire is too heavily damaged, have the vehicle recovered to a tire repair center to have the tire inspected. See [“Vehicle Recovery”, page 7-42](#).

A puncture will eventually cause the tire to lose pressure, which is why frequent checking of tire pressures is important. Punctured or damaged tires must be permanently repaired or replaced as soon as possible by an ElectraMeccanica Authorized Service Provider or a tire repair center.

Tire repair canister

⚠ WARNING Driving on a flat tire will cause permanent damage to the tire. Reinflating a tire after it has been driven on while severely underinflated or flat may cause a blowout, which can result in a serious collision. Never attempt to reinflate a tire that has been driven on while severely underinflated or flat.

Your vehicle does not have a spare wheel. A tire repair canister is supplied in the trunk in case you experience a leak in one of the tires.

Follow the manufacturer's instructions printed on the canister to inflate the tire. If the tire fails to inflate, call roadside assistance to have the vehicle transported to a tire repair center. See [“Transporting the Vehicle”, page 7-42](#).

Note: The tire repair canister is provided as a temporary repair solution that may allow you to drive the vehicle to a tire repair center and have the tire professionally repaired. Using the tire repair canister is not a permanent fix to the tire.



Tire Pressures

⚠️ WARNING Underinflation is the most common cause of tire failure and may result in severe tire cracking and tread separation (i.e. “blowout”), with unexpected loss of vehicle control and increased risk of injury.

Correctly inflated tires will ensure that you enjoy the best combination of vehicle range, tire life, ride comfort, and road handling.

You should check each tire monthly when cold and inflated to the inflation pressure recommended by the vehicle manufacturer on the vehicle placard or tire inflation pressure label, which is located in the lower frame of the right door.

Driving on a significantly underinflated tire causes the tire to overheat and can lead to tire failure. Underinflation also reduces battery range and tire tread life, and may affect the vehicle’s handling and stopping ability.

Checking and adjusting tire pressures

⚠️ WARNING This vehicle does not have a Tire Pressure Monitoring System (TPMS). Tire pressures should be checked with each pre-drive inspection, and checked at least once per month. See [“Pre-Drive Inspections”, page 2-5.](#)

⚠️ WARNING Tire pressures should be checked using an accurate pressure gauge when the tires are cold and the vehicle has been stationary for more than three hours. A hot tire at or below recommended cold inflation pressure is dangerously underinflated.

⚠️ WARNING If the vehicle has been parked in strong sunlight or used in high ambient temperatures, do not reduce the tire pressures. Move the vehicle into the shade and allow the tires to cool before checking.

Always inflate your tires to the recommended inflation pressure, even if it is different from the maximum inflation pressure information found on the tire itself.

Always replace the valve stem cap after adjusting tire pressures.

Note: It is an offense in certain countries to drive a vehicle with incorrect tire pressures.



Recommended COLD tire pressures

Tire Position	Tire Pressure	
Front	228 kPa	33 psi
Rear	234 kPa	34 psi

Note: When driving in ambient temperatures less than 41°F (5°C), the handling and ride quality of the vehicle can be improved by reducing the tire pressures by 5 psi (34 kPa). Return tire pressure to the normal recommendations when ambient temperatures increase.

Tire pressures during long-term storage

WARNING Tire pressures must be reduced to the recommended cold tire pressure for each tire before the vehicle is driven. Failure to do so can affect the handling of the vehicle, which could lead to a collision.

To minimize the possibility and effects of flat spots during storage, the tires may be inflated to the maximum pressure indicated on the tire wall. See [“Tire Markings”, page 7-19](#).

Replacement Wheels and Tires

WARNING For your safety, it is recommended that **ONLY** wheels and tires that match the original vehicle specification are used on the vehicle. Changing the width or profile of a tire or tires can change the

driving characteristics of the vehicle, which can lead to issues with the vehicle dynamics and handling. This increases the risk of loss of control and a collision.

Wheel rims and tires are matched to suit the handling characteristics of your vehicle. Always check that replacement tires comply with the original specification. See [“Vehicle Specifications”, page 1-9](#).

Ideally, you should replace tires in axle sets; in the case of your SOLO, this applies only to the front tires. When tires are replaced, the wheels should always be balanced and the alignment checked.

Tire Chains Prohibited

WARNING Do not use tire chains; there is not enough clearance on the vehicle. Tire chains used on a vehicle without the proper amount of clearance can cause damage to the brakes, suspension, or other vehicle parts. These repairs would not be covered by the vehicle warranty. The area damaged by the tire chains could cause loss of control and a collision.

WARNING Do not operate the SOLO on snowy or icy roads.



Tire Markings

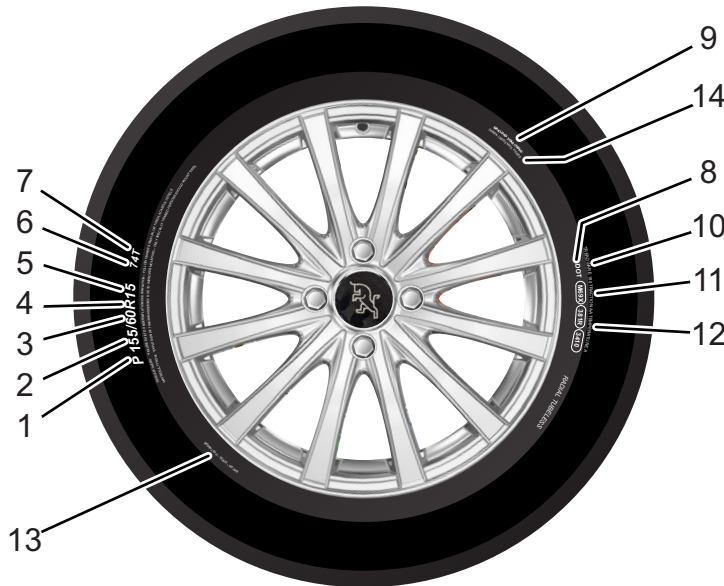

Federal law requires tire manufacturers to place standardized information on the sidewall of all tires. This information identifies and describes the fundamental characteristics of the tire, and provides the Tire Identification Number (TIN) for

safety standard certification and in case of a recall.

1. Tire category

P indicates that the tire is for passenger vehicles.

Note: Not all manufacturers show the tire category in the TIN.

2. Tire width

This three-digit number gives the width in millimeters of the tire from sidewall edge to sidewall edge.

3. Aspect ratio

This two-digit number, also known as the profile, gives the sidewall height as a percentage of the tread width. For example, if the tread width is 205 mm and the aspect ratio is 50, the sidewall height will be 102 mm.

4. Tire construction

R indicates that the tire is of radial-ply construction.



5. Wheel diameter

This two-digit number is the diameter of the wheel rim in inches.

6. Load index

This two- or three-digit number is the tire's load index, which is a measurement of how much weight each tire can support. This number is not always shown.

7. Speed rating

The speed rating, when stated, denotes the maximum speed at which the tire should be used for extended periods. The ratings range from 99 mph (160 km/h) to 186 mph (300 km/h). These ratings are listed in the following table:

Rating	Speed (mph)	Speed (km/h)
Q	99	160
R	106	170
S	112	180
T	118	190
U	124	200
H	130	210
V	149	240
W	168	270
Y	186	300

8. US DOT Tire Identification Number (TIN)

This begins with the letters "DOT" and indicates that the tire meets all federal standards. The next two numbers or letters are the plant code where it was manufactured, and the last four numbers represent the week and year the tire was built (for example, "1706" would mean the 17th week of 2006). The remaining numbers are marketing codes used at the manufacturer's discretion. This information can be used to contact consumers if a tire defect requires a recall.

9. Maximum permissible inflation pressure

This is the maximum inflation pressure for the tire. This pressure should not be used for normal driving.

10. Treadwear grade

This number indicates the tire's wear rate. The higher the treadwear number is, the longer it should take for the tread to wear down. For example, a tire rated at 400 will last twice as long as a tire rated at 200.

11. Traction grade

This letter indicates a tire's ability to stop on wet pavement. A higher-graded tire should allow you to stop your vehicle on wet roads in a shorter distance than a tire with a lower grade.

Traction is graded from highest to lowest as **AA**, **A**, **B**, and **C**.



12. Temperature grade

This indicates the tire's heat-resistance grading. The tire's resistance to heat is grade **A**, **B**, or **C**, with **A** indicating the greatest resistance to heat. This grading is provided for a correctly inflated tire, which is being used within its speed and loading limits.

13. Tire composition and materials

This number indicates the number of plies (layers of rubber-coated fabric) in the tire tread and sidewall. Information is also provided on the type of ply materials used.

14. Maximum tire load

The maximum load which can be carried by the tire.

Uniform Tire Quality Grading

The following information relates to the tire grading system developed by the National Highway Traffic Safety Administration (NHTSA), which grades tires by treadwear, traction, and temperature performance.

Note: *Winter tires and tires with deep tread are exempt from these marking requirements.*

Quality grades, where applicable, can be found on the tire sidewall between the tread shoulder and maximum section width. For example:

TREADWEAR 200	TRACTION AA	TEMPERATURE A
---------------	-------------	---------------

In addition to the marking requirements, passenger car tires must conform to federal safety requirements.

Treadwear

The treadwear grade is a comparative rating based on the wear rate of the tire when tested under controlled conditions on a specified government test course.

For example, a tire graded **150** would wear one and one-half (1 1/2) times as well on the government course as a tire graded **100**. The relative performance of tires depends upon the actual conditions of their use, however, and may depart significantly from the norm due to variations in driving habits, service practices, and differences in road characteristics and climate.



Traction

 **WARNING** The traction grade assigned to this tire is based on straight-ahead braking traction tests, and does not include acceleration, cornering, hydroplaning, or peak traction characteristics.

The traction grades, from highest to lowest, are AA, A, B, and C. Those grades represent the tire's ability to stop on wet pavement as measured under controlled conditions on specified government test surfaces of asphalt and concrete. A tire marked C may have poor traction performance.

Temperature

 **WARNING** The temperature grade for this tire is established for a tire that is properly inflated and not overloaded. Excessive speed, underinflation, or excessive loading, either separately or in combination, can cause heat buildup and possible tire failure.

The temperature grades are A (the highest), B, and C, representing the tire's resistance to the generation of heat and its ability to dissipate heat when tested under controlled conditions on a specified indoor laboratory test wheel.

Sustained high temperature can cause the material of the tire to degenerate and reduce tire life, and excessive temperature can lead to sudden tire failure.

The grade C corresponds to a level of test performance which all passenger car tires must meet under the Federal Motor Safety Standard No. 109.

Grades B and A represent higher levels of performance on the laboratory test wheel than the minimum required by law.



Tires and Wheels Glossary

Accessory weight

The combined weight (in excess of those items replaced) of items available as factory installed equipment.

Bead

The inner edge of a tire that is shaped to fit to the rim and form an air-tight seal. The bead is constructed of steel wires which are wrapped, or reinforced, by the ply cords.

COLD tire pressure

The air pressure in a tire which has been standing in excess of 3 hours, or driven for less than 1 mile (2 km).

Curb weight

The weight of a standard vehicle, including any optional equipment fitted, and with the correct fluid levels.

Gross Axle Weight Rating (GAWR)

The maximum distributed weight that may be supported by an axle on the vehicle.

Gross Vehicle Weight Rating (GVWR)

The maximum permissible weight of a vehicle with driver, passengers, load, luggage, and equipment.

kPa (kilo pascal)

A metric unit used to measure pressure. One kilo pascal equals approximately 0.145 PSI.

Maximum inflation pressure

The maximum pressure to which the tire should be inflated. This pressure is given on the tire sidewall in PSI (lbf/in²).



CAUTION

This pressure is the maximum allowed by the tire manufacturer. It is not the pressure recommended for use.

Maximum loaded vehicle weight

The sum of curb weight, accessory weight, vehicle capacity weight, and production options weight.

Production options weight

The combined weight of options installed which weigh in excess of 2 lb (1 kg) more than the standard items that they replaced, and are not already considered in curb or accessory weights.

PSI (lbf/in²)

Pounds per square inch, a unit of measurement for pressure.



Recommended tire inflation pressure

Tire inflation pressure, established by ElectraMeccanica, which is based on the type of tires that are mounted on the vehicle at the factory.

This information can be found on the Tire and Loading Information label located on the frame of the right door.

Rim

The metal support for a tire, or tire and tube, upon which the tire beads are seated.

Tread

The portion of a tire that comes into contact with the road.

Tread Wear Indicators (TWI)

The projections within the principal grooves designed to give a visual indication of the degrees of wear of the tread.

Vehicle capacity weight

The number of seats multiplied by XXX lb or XXX kg plus the rated amount of load/luggage.





Headlight/Bulb Replacement

The lights on your vehicle are a mixture of long-life Light Emitting Diodes (LED) and halogen bulbs, which are not repairable or user-replaceable. Please contact your ElectraMeccanica Authorized Service Provider for service.

Fuses



WARNING

Always use the recommended fuse. A specification list can be found inside each fuse box cover. Using a fuse above or below the recommended rating can result in vehicle damage, overheating, or fire.

Whenever there is an excessive amount of current flowing through a circuit, the fusible element will melt and create an open or incomplete circuit. Fuses are a one-time protection device and must be replaced each time the circuit is overloaded. Replace the fuse with one of equal current and voltage rating. If a fuse melts repeatedly, have the electrical system inspected by your ElectraMeccanica Authorized Service Provider.

There are two fuse centers. One is located under the hood, and the other is behind a service panel to the right of the accelerator pedal.



Accessing the Fuse Centers

Note: For your reference, a diagram of the fuse center layout is printed on the inside of each cover.

To access the under-hood fuse center:

1. Open the hood. See [“Hood”, page 4-28](#).

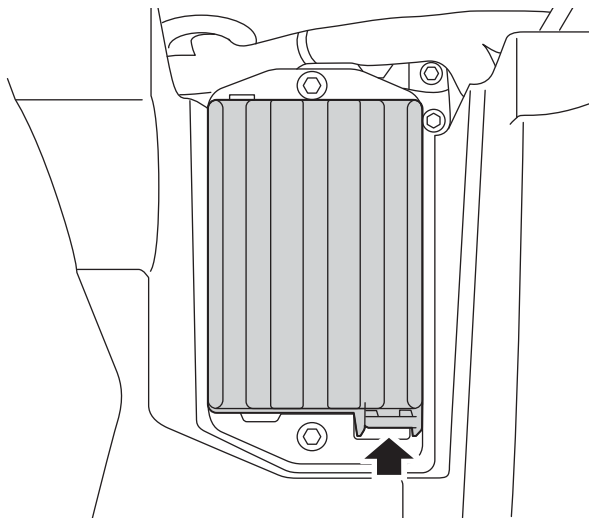

2. Push in on the tab to unlatch the fuse center cover, then pull up to remove it.

To access the interior fuse center:

1. Locate the access panel, which is in the wall of the footwell, to the right of the accelerator pedal.

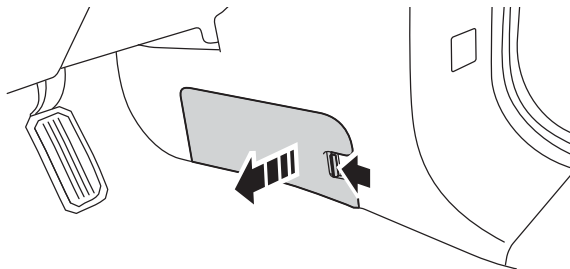

2. Push in on the tab to unlatch the access panel, then pull outward to remove it and reveal the fuse center.

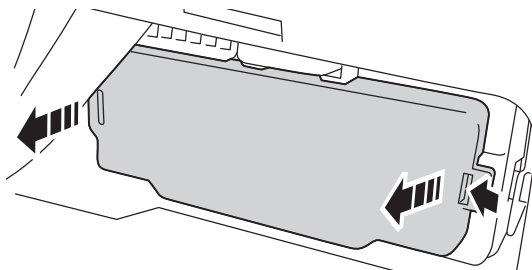

3. Push in on a tab to unlatch the fuse center cover, then pull outward to remove it.



Under-Hood Fuse Center

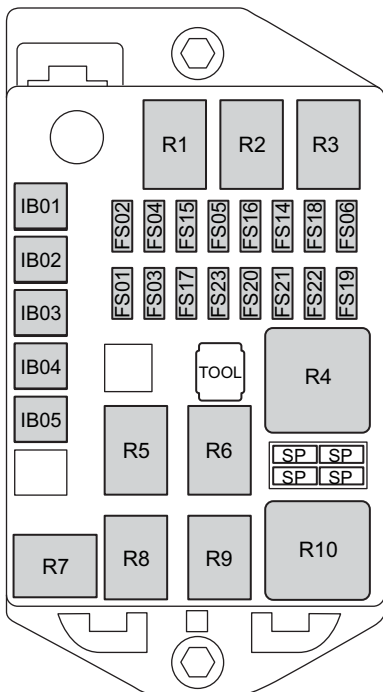

Note: A fuse-pulling tool is stored in the middle of the fuse center.

Note: There are four spare fuses (SP) of varying ratings grouped together toward the upper left side of the fuse center.

Fuse	Rating	Usage
FS01	10A	Battery Management System
FS02	5A	Battery Management System
FS03	5A	On-Board Charger
FS04	5A	Motor Controller
FS05	10A	Heating, Ventilation, & Air Conditioning
FS06	20A	Blower
FS14	10A	Vacuum Pump
FS15	5A	Electronic Power Steering & Electronic Parking Brake Controllers
FS16	15A	Thermal Management System & Motor Controller Coolant Pumps
FS17	5A	Electronic Parking Brake Switch
FS18	10A	Seat Heater
FS19	10A	Horn
FS20	5A	Auxiliary Low Beam
FS21	5A	High Beam
FS22	10A	Motor Controller Fan
FS23	5A	Low Beam



Fuse	Rating	Usage
IB01	20A	Front Radiator Fan
IB02	30A	Remote Battery Terminal
IB03	30A	Electronic Parking Brake Motor
IB04	30A	Distribution 1
IB05	30A	Distribution 2

Relay	Usage
R1	Motor Controller Pump Relay
R2	Battery Cooling Pump Relay
R3	AC Wakeup Relay
R4	Low Beam Relay
R5	Auxiliary Low Beam Relay
R6	High Beam Relay
R7	Front Radiator Fan Relay
R8	Motor Controller Radiator Fan Relay
R9	Horn Relay
R10	Blower Relay





Interior Fuse Center

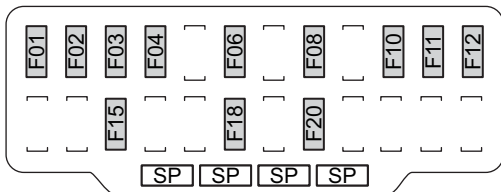

Note: There are spare fuses (SP) of varying ratings in the blank positions and the lower positions of the fuse center.

Fuse	Rating	Usage
F01	20A	Power Window (Left)
F02	10A	Display
F03	10A	Radio/Mirror Control
F04	10A	Thermal Management System
F06	10A	Radio
F08	10A	Display/OBDII
F10	5A	Interior Lamp
F11	15A	Wiper
F12	15A	Power Door Lock
F15	20A	Power Window (Right)
F18	5A	Mirror Defrost
F20	10A	Motor Control



Batteries

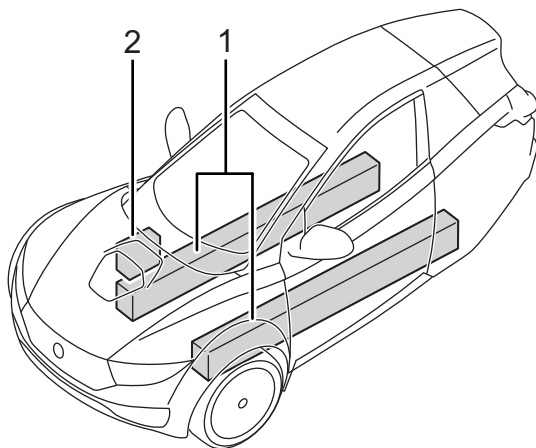

1. High-voltage 144V

⚠ WARNING The high-voltage batteries have no user-serviceable parts. Do not disassemble, remove or replace high-voltage components, cables or connectors. High-voltage cables are colored orange for easy identification.

The 144V high-voltage batteries are located along the length of the chassis on both sides of the seat, from front to rear. See

[“About the High-Voltage Battery”, page 5-2](#) for more information.

2. Low-voltage 12V

The 12V accessory battery is located inside the vehicle, to the right of the accelerator pedal.

About the 12V Battery

Your vehicle is equipped with a maintenance-free 12V accessory battery, which powers all of the standard 12V on-board electronics and the built-in charging system for the high-voltage battery.

During normal use, the high-voltage battery charges the 12V battery in order to keep all electrical systems functioning. When your vehicle is OFF, the 12V battery maintains the electrical systems, and the high-voltage battery maintains the charge level in the 12V battery.



Charging the 12V Battery

WARNING Never attempt to charge the 12V battery while the high-voltage battery is being charged. Doing so could damage the vehicle or charging equipment, and could cause an injury.

WARNING Keep any sparks or flames away from the 12V battery. Explosive gases are always present near the 12V battery and could cause death or severe injury if ignited.

WARNING Battery fluid is corrosive and can cause severe burns. Do not allow battery fluid to come into contact with eyes, skin, clothing, or painted surfaces. Immediately flush any contacted areas with copious amounts of water.

WARNING Battery posts, terminals, and related accessories contain lead and lead compounds. Wash your hands thoroughly after handling any battery components.

CAUTION Any power source (e.g. battery, charger) used to charge your vehicle must be rated as 12V. Using an improperly-rated power source can damage your vehicle, which would not be covered under warranty.

CAUTION Never use the 12V battery in your vehicle to jump-start other vehicles, as the electrical system is not designed for it. Doing so can cause

severe damage to your vehicle, which would not be covered under the warranty.

In certain circumstances (e.g. leaving the vehicle idle or in storage for too long), the 12V battery may have an insufficient level of charge to operate the on-board electrical systems.

There may be insufficient charge in the 12V battery if:

- The vehicle will not power on when the key switch is in the ON position (see [“Key Switch”, page 4-6](#)).
- The vehicle will not charge when the charge cable is plugged in (see [“Using the Charge Cable”, page 5-3](#)).

If the 12V battery lacks sufficient charge to power these systems, it can be charged using the methods in this section.

Note: Charging the 12V battery will not affect the charge level of the high-voltage battery. You can only charge the high-voltage battery via the charge cable. See [“Charging the Vehicle”, page 5-3](#).

Note: If you experience persistent issues with your 12V battery's state of charge, have your vehicle inspected by an ElectraMeccanica Authorized Service Provider.



Locating the 12V battery terminals

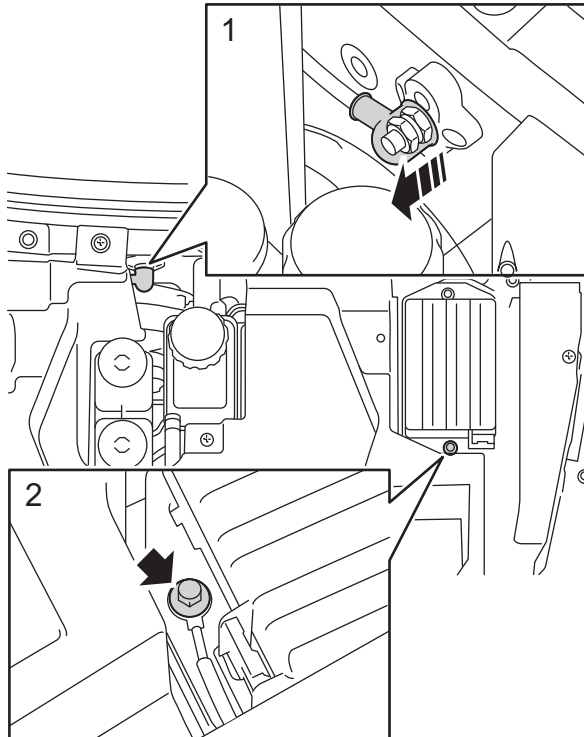

Your vehicle's 12V battery terminals are located under the hood as follows:

1. The positive (+) terminal is located behind the fluid reservoirs. Remove the cap to expose the terminal.
2. The negative (-) terminal is located near the base of the fuse box.



Charging the 12V battery

WARNING Before connecting a charger, ensure that your vehicle is powered OFF with the Electronic Parking Brake engaged. See [“Electronic Parking Brake \(EPB\)”](#), page 4-18.

WARNING Ensure that your vehicle is parked in a well-ventilated area and sheltered from rain. Excess explosive gases can build up in an enclosed structure and result in an explosion.

WARNING The 12V battery must only be charged via the under-hood terminals unless the battery has been removed from the vehicle.

WARNING If charging the 12V battery when removed from the vehicle, do not allow the charger's clips to contact each other if a clip is connected to a battery. If the clips touch while electrical current is running through them, they can spark and potentially cause a fire.

WARNING Always follow the instructions and precautions written by the manufacturer of your charger.

Some battery chargers (e.g. trickle chargers) can safely be left connected for months without harming your 12V battery, while others may only be left connected for much shorter periods. Read your charger's manual for details.

To connect a portable battery charger or trickle charger to the 12V battery:

1. Ensure that your vehicle is in N (Neutral) with the Electronic Parking Brake engaged, and the key switch is in the OFF position. See [“Parking”](#), page 6-7.
2. Ensure that the charge cable for the high-voltage battery is not connected to your vehicle. See [“Disconnecting the Charge Cable”](#), page 5-7.
3. Open the hood of your vehicle. See [“Hood”](#), page 4-28.
4. Remove the cap from your vehicle's positive (+) terminal. See [“Locating the 12V battery terminals”](#), page 7-32.
5. Connect the charger's clips securely to the vehicle in the following order:
 - Positive (red) clip to your vehicle's positive (+) terminal.
 - Negative (black) clip to ground on your vehicle, as far away from the battery as possible. A proper grounding point is a clean, unpainted, metallic part of your vehicle's frame or chassis.
6. Ensure that your charger is set to the proper settings for a 12V battery as per the manual's recommendations. Connect your charger to a power source and turn it on.



7. Check the charger's display to ensure it is charging properly.
If the battery fails to begin charging after a few minutes:
 - Most chargers have an amp meter that reads higher on a dead battery, and lower to 0 on a fully-charged one. If the meter reads low, the battery may not need a charge.
 - Your ground connection may not be adequate. Turn off the charger, unplug it, and retry the negative (black) clip connection to ground on your vehicle.
 - If none of the above conditions apply, there may be an underlying issue with the battery. Stop attempting to charge it and disconnect the clips as directed in the following steps. Have the vehicle inspected by an ElectraMeccanica Authorized Service Provider.
8. Once the battery is sufficiently charged, turn off the charger and disconnect the clips in the reverse order in which they were connected:
 - Negative (black) clip from ground on your vehicle.
 - Positive (red) clip from your vehicle's positive (+) terminal.
9. Replace the cap over your vehicle's positive (+) terminal and close the hood.





Remote Keyless Entry (RKE) Transmitter Battery Replacement

⚠️ WARNING If swallowed, a battery can cause internal burns, severe injury, or death. Keep batteries out of reach of children. Seek medical attention immediately if a battery is swallowed.

 Environmental Notice: Refer to local regulations when disposing of batteries.

See [“Parts and Maintenance Items”, page 7-2](#) for the battery type specified for your remote transmitter.

To replace the remote transmitter battery:

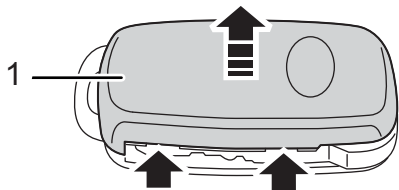

1. Using a small, flat-bladed screwdriver, carefully pry to release the outer back cover of the remote transmitter at the illustrated points.

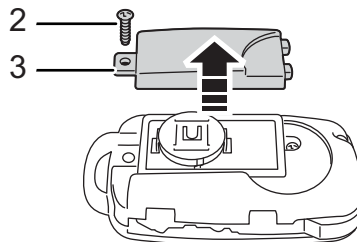

2. Remove the screw from the battery cover.
3. Remove the battery cover.

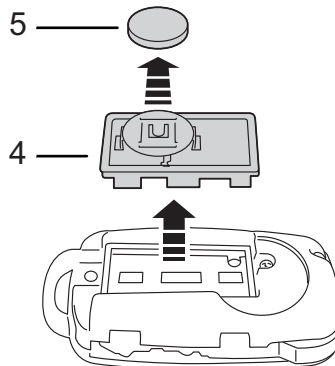

4. Remove the battery module from the remote transmitter.



5. Slide the old battery sideways out of the holder, observing the +/- symbols on the battery, and replace with a new battery.
6. Reassemble the remote transmitter.
7. Test the operation of the remote transmitter. See [“Remote Transmitter”, page 4-26.](#)

If you are experiencing problems with the remote transmitter after changing the battery, contact your ElectraMeccanica Authorized Service Provider.





Washing the Vehicle

CAUTION Improper cleaning can damage electrical components, cowlings, panels, and other plastic parts. Do not use high-pressure water or steam cleaners; they can cause water intrusion of bearings, seals, and electrical components.

CAUTION Do not use any harsh chemicals or abrasive cleaning products on plastic parts, and do not use cloths or sponges that have been in contact with such materials. Examples of products that could damage plastic parts include: solvent or thinner, gasoline or other fuels, rust removers or inhibitors, brake fluid, antifreeze, or electrolytes.

 Environmental Notice: It is illegal to pollute drains, rivers and waterways. Some cleaning products contain chemicals that are hazardous to the environment. All toxic chemicals must be disposed of at authorized waste disposal sites only. Always take precautions to prevent fluids from spilling.

To prolong the life of your vehicle, it should be washed periodically. Regular cleaning is an important factor in maintaining the value of your vehicle. It also ensures that safety-related parts remain in full working order.

If dirt, tar, bugs, or other similar deposits have accumulated, clean them off as soon as possible.

Note: It is recommended to use a garden hose to wash your vehicle. High-pressure washers (like those at self-service car washes) can damage certain parts.

Vinyl care and maintenance

Vinyl wrap requires regular maintenance in order to stay vibrant. To prolong the condition of the vinyl wrap, keep it clean and out of direct sunlight as much as possible.

Vinyl care instructions:

- ElectraMeccanica recommends washing by hand at least once a week.
- Use a mild cleansing detergent and water mix that does not contain any strong soluble substances, citrus, petroleum distillates, or abrasive components. The detergent should have a pH between 5 and 9.
- Do not wipe dusty surfaces directly. Wash first with soapy water before wiping down with a soft, clean towel.
- Test the cleaning product on an inconspicuous area first.
- Remove tree sap, bird droppings, or other contaminants as soon as possible.
- Do not use high-pressure washers or drive-through car washes.



Cleaning the heated seat



CAUTION Do not apply any liquids directly to the heated seat. Wipe up any spills immediately.

Use a soft cloth to clean the heated seat. If necessary, dampen the cloth sparingly with water to remove any stains.

Cleaning the back-up camera

To clean the back-up camera, always use glass cleaner and a microfiber cloth to avoid scratching or otherwise damaging the lens.

Floor Mat



WARNING A loose or improperly-fitted floor mat could interfere with the operation of the foot pedals, potentially leading to loss of vehicle control and a collision.



WARNING Do not place additional floor mats over an existing one.



WARNING Always install a floor mat with the correct side facing up. Do not turn it over.

Using a genuine SOLO floor mat can extend the life of the vehicle's carpet and make it easier to clean. The mat should be cleaned regularly and replaced if it becomes worn or damaged.

Inspect the floor mat periodically to ensure it is properly installed. Depress each foot pedal fully and reinstall the mat if any interference is felt.



Parking and Long-Term Storage

WARNING Never attempt to charge the 12V battery while the high-voltage battery is being charged. Doing so could cause personal injury, and could damage the vehicle or charging equipment.

CAUTION It is NOT recommended to leave the charge cable connected to the vehicle during long-term storage, as this will lead to faster battery degradation.

CAUTION Do not store the vehicle for more than 1 month when the charge level of the high-voltage battery is above 70% or below 30%.

Storing your SOLO requires certain maintenance procedures before, during, and after storage in order to maintain battery health and vehicle performance.

Before entering storage

To prepare your SOLO for storage:

- Ensure that the storage environment will protect the vehicle from ambient temperatures below -4°F (-20°C) or above 122°F (50°C).
- Wash the vehicle and dry it completely.
- Wax the vehicle.
- Check and adjust the tire pressure on all tires. See [“Tire pressures during long-term storage”, page 7-18.](#)
- Ensure that the state of charge of the high-voltage battery is within the recommended range for the vehicle’s storage time (see table).
- Connect a trickle charger to the 12V battery terminals to maintain battery health during storage. See [“Charging the 12V Battery”, page 7-31.](#)

Storage Time	Ideal Charge Level	Recommended Charge Range
Less than 2 months	30%	Between 30% - 70%
More than 2 months	40%	Between 40% - 60%



During storage

The high-voltage battery will need to have its charge level checked monthly and maintained according to the previous table.

To maintain the charge level during storage:

1. Disconnect the trickle charger from the 12V battery.
2. Charge the high-voltage battery to 100%. See [“Charging the Vehicle”, page 5-3.](#)
3. Discharge the high-voltage battery to 0%. This can be done by driving the vehicle and/or running the climate controls continuously.
4. Immediately after the state of charge reaches 0%, charge the high-voltage battery to the ideal charge level listed in the previous table.
5. Disconnect the charge cable.
6. Reconnect the trickle charger to the 12V battery.

Removing from storage

When removing the vehicle from storage, perform a pre-drive inspection before driving. See [“Pre-Drive Inspection Checklist”, page 2-5.](#)





Jacking and Lifting the Vehicle

WARNING Never raise the vehicle when the charge cable is connected, even if charging is not in progress. Always disconnect the charge cable before raising the vehicle.

WARNING The illustrated lifting points are the only approved lifting points for your vehicle. Using any other lifting points may cause the vehicle to fall, resulting in death or injury to anyone in its vicinity. Lifting the vehicle at any other points may cause irreparable damage to the vehicle. The repairs would not be covered by the vehicle warranty.

CAUTION Use a suitable rubber or wooden pad between the jack and the vehicle body to prevent surface damage.

Note: This vehicle does not come with a jack. The best way to raise the vehicle is to take it to a service station that can use a vehicle lift.

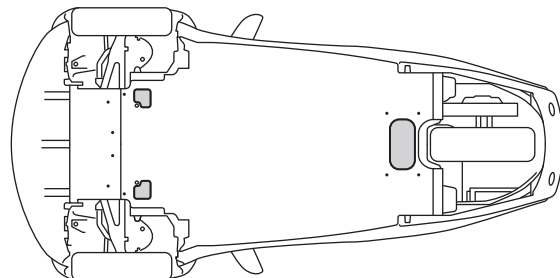

If you need to lift your vehicle with a jack, follow the manufacturer's instructions for the jack you are using, and only use the illustrated lifting points.



Transporting the Vehicle

WARNING

Never allow passengers to ride on a trailer or flatbed transporter, or in a trailered vehicle.

CAUTION

Do not use the recovery eye to strap the vehicle down.

CAUTION

Towing the vehicle with the wheels on the ground, or on a suspended lift, may cause serious damage to the vehicle and its electrical components. The repairs would not be covered by the vehicle warranty.

If for any reason your vehicle can not be driven, the only approved method of recovering or transporting it is by using a flatbed trailer or transporter with an approved load rating greater than the actual weight of your vehicle, including aftermarket accessories and cargo. See [“Vehicle Specifications”, page 1-9](#) for weight estimations.

Note: The 12V battery must be charged if it does not have sufficient power to release the Electronic Parking Brake (EPB). See [“Charging the 12V Battery”, page 7-31](#).

Preparing the vehicle for loading

Before loading your vehicle, follow these steps:

1. Turn the key switch to the ON position. See [“Key Switch”, page 4-6](#).

Note: Do NOT turn the key switch to START. The vehicle should not be in READY mode at this time.

2. Set the Drive Mode Selector to N (Neutral). See [“Drive Mode Selector”, page 4-7](#).
3. Disengage the EPB. See [“Electronic Parking Brake \(EPB\)”, page 4-18](#).
4. Leave the key switch in the ON position while the vehicle is loaded to prevent the EPB from engaging.



Loading the vehicle

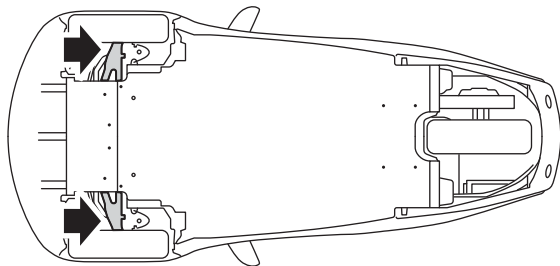

Use the two lower control arms (illustrated) as the hook/attaching points to pull the vehicle onto a trailer or transporter.

After loading your vehicle onto an approved trailer or flatbed transporter, follow these guidelines:

1. Turn the key switch to the **ON** position. See [“Key Switch”, page 4-6.](#)
2. Set the Drive Mode Selector to **N**. See [“Drive Mode Selector”, page 4-7.](#)
3. Engage the Electronic Parking Brake. See [“Electronic Parking Brake \(EPB\)”, page 4-18.](#)
4. Turn the key switch to the **OFF** position, and remove the key to prevent loss.

5. Secure all cargo and other items, or remove them from the vehicle.
6. Ensure that the hood, trunk, and both doors are closed securely.
7. Block all wheels at the front and rear of each tire.

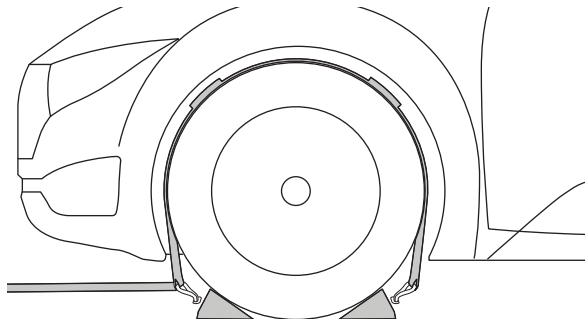

8. Use tire wheel straps or loop straps (illustrated) to secure the vehicle to the trailer or flatbed transporter.
9. Reduce speed and drive with caution while transporting the vehicle.

Note: Repairs for damage caused by any recovery method will not be covered by the vehicle warranty.



Using the Recovery Eye

⚠ WARNING A towing line under tension is hazardous; if it fails, it can strike people and cause serious injury or death. Follow all warnings and instructions provided with the towing line and winch. Use only lines designed and rated to pull a vehicle of this weight. See [“Vehicle Load Limits”, page 2-3.](#)

⚠ WARNING Do not manually disengage the Electronic Parking Brake (EPB) until the vehicle is ready to be pulled, with the recovery eye assembled and the towing line attached. Disengaging the EPB leaves the vehicle freewheeling and it could roll unexpectedly, causing personal injury, vehicle damage, or property damage. See [“Electronic Parking Brake \(EPB\)”, page 4-18.](#)

⚠ CAUTION Before pulling the vehicle, always ensure that the recovery eye bolt is fastened securely.

⚠ CAUTION After fastening the recovery eye bolt and attaching a tow line, release the EPB before pulling the vehicle (see [“Electronic Parking Brake \(EPB\)”, page 4-18.](#)). Pulling the vehicle with the EPB engaged could cause damage to it, which would not be covered by the warranty.

In the event that your vehicle needs to be pulled onto a flatbed trailer or transporter, a recovery eye assembly is supplied for this purpose. Once assembled, a towing line (e.g. a strap, chain, or cable) can be attached to the recovery eye and used to pull the vehicle onto a transporter.

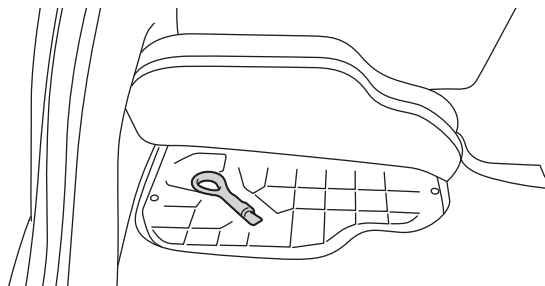

1. The recovery eye is located in a storage area under the trunk floor. Pull up on the carpeted cover to access the recovery eye.

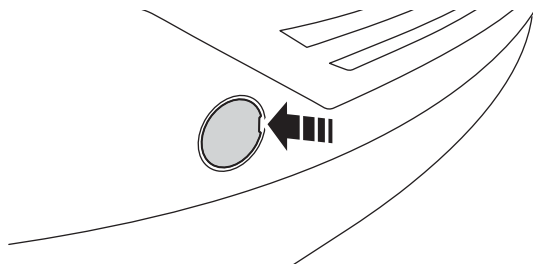

2. The mounting point for the recovery eye is behind a cover located to the right of the grill. To remove this cover, insert a flat-bladed tool (such as a screwdriver) into the slot along the edge, then gently pry up until it releases.

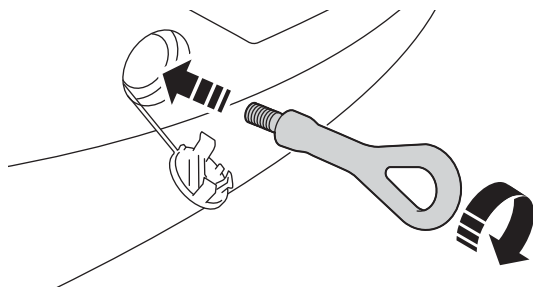

3. Insert the recovery eye fully into the mounting point, then rotate clockwise until it is tightly fastened.

4. Check the recovery eye to ensure it is securely fastened, then attach the towing line.
5. Release the Electronic Parking Brake (EPB) before pulling the vehicle. See [“Electronic Parking Brake \(EPB\)”](#), page 4-18.

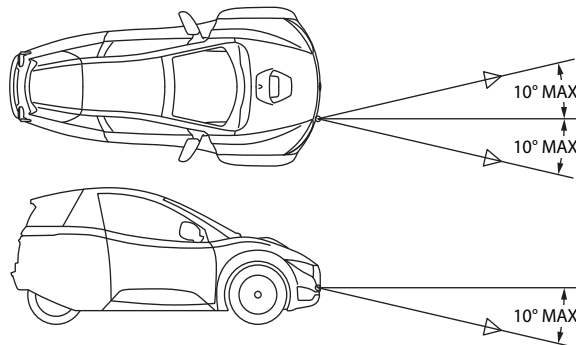

6. The recovery eye has a limited range in which it can be pulled from, as seen in the illustration. Do not pull the vehicle from an angle outside of this range.



A series of 15 horizontal dashed lines spanning the width of the page, providing a template for writing notes.



Customer Assistance

Please have the following available when contacting ElectraMeccanica, as they are essential to effectively and efficiently answer your questions or resolve your concerns.

- Owner's name and address
- Owner's telephone number
- Date of purchase
- Vehicle Identification Number (VIN)

To locate the VIN, see [“Vehicle Identification Number \(VIN\)”, page 1-8.](#)

ElectraMeccanica can be contacted as follows:

EMV Automotive USA Inc.
11647 Ventura Boulevard
Studio City, CA
91604
USA

Phone: +1 888 457 SOLO (+1 888 457 7656)

Monday-Friday 9am to 5pm (Pacific Time)

E-mail: customersupport@electrameccanica.com

To find your local ElectraMeccanica Authorized Service Provider, please check the SOLO app or go to:

<https://electrameccanica.com/service>

Note: For warranty information, refer to the Limited Warranty Manual, which is a separate document.



Reporting Safety Defects

United States

If you believe that your vehicle has a defect which could cause a collision or could cause injury or death, you should immediately inform the National Highway Traffic Safety Administration (NHTSA) in addition to notifying ElectraMeccanica.

If NHTSA receives similar complaints, it may open an investigation. If it finds that a safety defect exists in a group of vehicles, it may order a recall and remedy campaign. However, NHTSA cannot become involved in individual problems between you, your dealer, or ElectraMeccanica.

To contact NHTSA, you may call the Vehicle Safety Hotline toll-free at:

+1 888 327 4236 (TTY: +1 800 424 9153)

or write to:

Administrator
National Highway Traffic Safety
1200 New Jersey Avenue SE
Washington, DC 20590

You can also contact NHTSA and obtain other information about motor vehicle safety at:

<https://www.safercar.gov>

Canada

If you believe that your vehicle has a defect which could cause a collision or could cause injury or death, you should immediately inform Transport Canada, in addition to notifying ElectraMeccanica.

To contact Transport Canada, call their toll-free number:

+1 800 333 0510

or write to:

Transport Canada
Road Safety Branch
80 rue Noel
Gatineau, QC J8Z 0A1



Service History

After you have had your SOLO serviced, please ensure that the appropriate maintenance record has been completed.

Use the space under Notes to record issues you want to remind yourself about or mention at the next service.

500-1,000 miles (750-1,500 km) or 6 months	
Odometer reading:	Date:
Notes:	
Performed by:	

10,000 miles (15,000 km) or 12 months	
Odometer reading:	Date:
Notes:	
Performed by:	

20,000 miles (30,000 km) or 24 months	
Odometer reading:	Date:
Notes:	
Performed by:	

30,000 miles (45,000 km) or 36 months	
Odometer reading:	Date:
Notes:	
Performed by:	

40,000 miles (60,000 km) or 48 months	
Odometer reading:	Date:
Notes:	
Performed by:	



50,000 miles (75,000 km) or 60 months	
Odometer reading:	Date:
Notes:	
Performed by:	

80,000 miles (120,000 km) or 96 months	
Odometer reading:	Date:
Notes:	
Performed by:	

60,000 miles (90,000 km) or 72 months	
Odometer reading:	Date:
Notes:	
Performed by:	

90,000 miles (135,000 km) or 108 months	
Odometer reading:	Date:
Notes:	
Performed by:	

70,000 miles (105,000 km) or 84 months	
Odometer reading:	Date:
Notes:	
Performed by:	

100,000 miles (150,000 km) or 120 months	
Odometer reading:	Date:
Notes:	
Performed by:	

Component Replacement Record



Replacement Record

Use the following table to keep a record of any components replaced (e.g. drive belt, brake pads, etc.).

Component(s) replaced	Odometer reading	Date replaced



Component Replacement Record

A series of 15 horizontal dashed lines, intended for recording component replacement information.



A

Accessories	1-5
Air	
Conditioning	4-29
Recirculation	4-29

B

Back-up camera	4-17
Cleaning	7-38
Batteries	7-30
12V	7-30
High-voltage	5-2
Battery	
Charge level indicator	4-9
Brake fluid	
Level	7-8
Specification	7-8
Braking	6-5
Regenerative	6-6
Bulb replacement	7-25

C

Cabin	
Air conditioning	4-29
Heat	4-29
Light	4-24
Ventilation	4-29
Charge cable	5-3
Charging	
12V	7-31
Estimating charging time	5-7
State of	4-9
The vehicle	5-3
Clock	4-9
Contact information	
ElectraMeccanica	8-1
NHTSA	8-2
Transport Canada	8-2
Coolant	7-12
Cup holder	4-35

D

Drive belt tension	7-13
Drive mode selector	4-7
Drive motor temperature	4-9
Driver requirements	1-4

**E**

Electric mirrors	4-5
Electric windows	4-31
Electronic Parking Brake (EPB)	4-18
Exterior lights	4-20
External ambient temperature	4-9

F

Flat tire	7-16
Floor mat	7-38
Fuse centers	
Accessing	7-26
Interior	7-29
Under-hood	7-27
Fuses	7-25

H

Hazard flashers	4-23
Headlight bulb replacement	7-25
Headlights	4-20
Heat	
Cabin	4-29
Seat	4-32
Hill Start Assist system	6-6

Hood	4-28
Horn	4-4

I

Indicator lights	4-14
Daytime running lights	4-14
Door ajar	4-14
Electronic parking brake	4-14
Fasten seat belt	4-14
Headlight high beam	4-14
Headlight low beam	4-14
Instrument cluster display	4-9
Interior fan	4-29
Interior lights	4-24

J

Jacking the vehicle	7-41
---------------------------	------

K

Key switch	4-6
------------------	-----



L

Lifting the vehicle	7-41
Lights	
Exterior	4-20
Interior	4-24
Locking the vehicle	4-27
Long-term storage	7-39

M

Maintenance	
Component locations	7-7
Cover	7-7
Initial required	7-2
Inspection service	7-5
Record	9-1
Schedule	7-4
Mirrors	4-5

P

Parking brake	4-18
Parking on hills and slopes	6-7
Parts and maintenance	7-2
Power gauge	4-9
Power mirrors	4-5
Power windows	4-31

R

Radio	4-2
Rear view camera	4-17
Cleaning	7-38
Recovery eye	7-44
Remote Keyless Entry (RKE)	4-26
Locking the vehicle	4-27
Rear trunk opening	4-27
Transmitter	4-26
Transmitter battery replacement	7-35
Unlocking the vehicle	4-27
Reporting safety defects	8-2
Required equipment	1-5

S

Safety information	1-3
Safety instructions	
Maintenance safety	7-3
Safe operation	2-1
Wearing seat belts when pregnant	3-6
Seat	
Adjustment	3-2
Cleaning	7-38
Heater	4-32



Seat belts	
Care	3-7
Fastening and releasing	3-5
Testing	3-7
Wearing seat belts correctly	3-4
Wearing when pregnant	3-6
Service	
History	9-1
Schedule	7-4
Specifications	1-9
Speedometer	4-9
Steering wheel adjustment	4-4

T

Temperature control	4-29
Tire chains prohibited	7-18
Tire Identification Number (TIN)	7-20
Tires	7-19
Care	7-14
Degradation	7-15
Grading	7-21
Markings	7-19
Pressures	7-17
Quality	7-21
Repair canister	7-16

Replacement of	7-18
Wear indicators	7-15
Transporting the vehicle	7-42
Trip distance reset	4-12
Trunk	4-34
Light	4-24
Opening with no power	4-34
Turn signals	4-22

U

Uniform tire quality grading	7-21
Unlocking the vehicle	4-27

V

Vehicle	
Dimensions	1-10
Load limits	2-3
Modifications	1-5
Range	1-6
Specifications	1-9
Telematics	1-7
Vehicle Identification Number (VIN)	1-8
Ventilation	4-29



W

Warning labels	1-5
Warning lights	4-15
Accessory battery	4-15
Battery management system	4-16
Brake warning	4-15
Charging fault	5-6
Combinations	4-16
Electronic power steering	4-16
EPB warning	4-15
Fault	4-15
Washing the vehicle	7-37
Wheel replacement	7-18
Windows	4-31
Windshield	
Defrost	4-30
Washer fluid	7-10
Washer operation	4-25
Wiper operation	4-25
Wiper blade	
Checking	7-11
Replacement	7-11





EMV Automotive USA Inc.
11647 Ventura Boulevard
Studio City, CA 91604

+1 888 457 7656
info@electrameccanica.com
<https://electrameccanica.com>